

Plan of decarbonisation of the domestic power industry through modernisation with the use of nuclear reactors

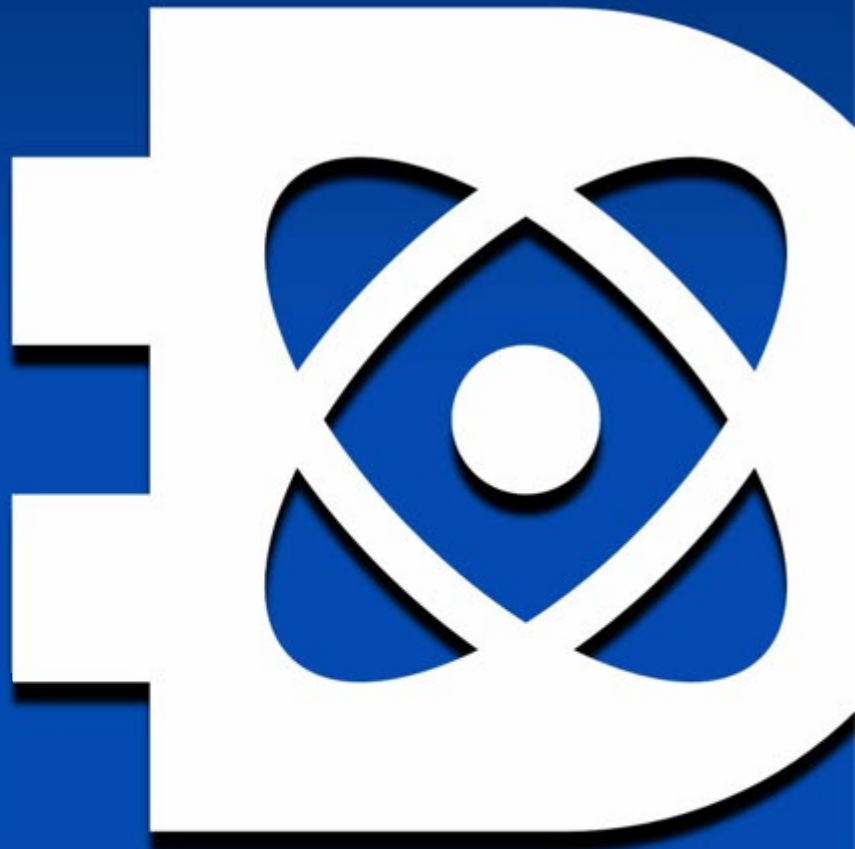

KM4.1 Preliminary feasibility studies for Generation III reactors – Kozenice

Contractor: Energoprojekt Katowice S.A.



Revision 00

Katowice, June 2025

1.	Basic information about the project	9
2.	Market analysis of investment demand	9
2.1.	Current characteristics of the electricity market in Poland	9
2.1.1.	Structure of electricity demand and supply	10
2.1.2.	Structure of installed capacity in the National Power System	14
2.2.	Forecast for the development of the electricity market in Poland	16
2.2.1.	Forecast of installed capacity	16
2.2.2.	PSE electricity demand forecast	19
2.2.3.	Analysis of the adequacy of generation sources	20
2.2.4.	Required additional available capacity	21
2.3.	Selection of optimal system structures	22
2.4.	Summary of the energy market analysis	25
3.	Detailed diagnosis of the technical condition of the existing infrastructure of the facility in terms of its potential use for the needs of a nuclear power plant, including the infrastructure necessary for the operation of the power plant, i.e., transmission networks, road and rail infrastructure, external and internal water sources	26
3.1.	General information	26
3.1.1.	Existing generating units	26
3.1.2.	Planned generating units	28
3.2.	BAT conclusions and related coal-fired power plant closures	29
3.3.	Characteristics of an open cooling system in the context of its use in a nuclear power plant	30
3.4.	"The Vistula threshold" – aspects of use and further operation in the context of nuclear power plant construction	33
3.5.	Characteristics of the existing district heating network	34
3.6.	Characteristics of the emergency power supply system	34
3.7.	Construction and road works	35
3.7.1.	Description of the existing development plan	35
3.7.2.	Description of the existing road system	35
3.7.3.	Description of the existing railway system	38
3.7.4.	Description of the geological and water conditions	40
3.7.4.1.	Identification of flood risk	42

3.8.	Electrical system for auxiliary power	43
3.9.	Power output	43
3.9.1.	General characteristics	44
3.9.2.	Block transformers	44
3.9.3.	Block transformer bays	44
3.9.4.	Power transmission lines	45
3.9.5.	Kozienice power station	45
3.9.6.	Other power engineering systems	47
3.10.	Water and wastewater infrastructure (excluding technical equipment)	47
3.11.	Diagnosis of the possibilities of using the existing infrastructure of the site – summary	48
4.	MARKET ANALYSIS OF THE SUPPLIERS OF TECHNOLOGY REQUIRED FOR THE INVESTMENT PROCESS	49
4.1.	Assumptions	49
4.2.	Market of Suppliers	50
4.3.	Recommendation of the reactor type (nuclear power plant) selected for further analysis	55
5.	DESCRIPTION OF THE ADOPTED SOLUTION	55
5.1.	General scope of dismantling works	55
5.2.	Recommendation of the type of cooling system selected for further analysis	56
5.3.	Modifications to the existing open-circuit cooling system	56
5.4.	Development area	57
5.5.	Preliminary technical description of the selected reactor	58
5.6.	Electrical system for auxiliary power supply	61
5.7.	Power output	61
5.7.1.	Legal framework	62
5.7.2.	Block transformers	63
5.7.3.	Block transformer bays	64
5.7.4.	Power transmission lines	64
5.7.5.	Expansion of the Kozienice power substation	65
5.8.	Power control system of a nuclear power plant	65
5.9.	Civil engineering and road works	66
5.10.	Technological assessments	69
6.	ESTIMATED CAPITAL EXPENDITURE	71
6.1.	CAPEX structure	71

6.2.	Methodology	72
6.3.	Determination of the percentage distribution of capital expenditure	72
6.4.	Determination of the unit construction cost of an AP-1000 unit according to press releases	74
6.5.	Determination of additional costs and savings related to the location of the planned investment	74
6.6.	CAPEX Estimate	76
6.7.	Comparison of Greenfield vs Brownfield	79
7.	ANALYSIS OF ECONOMIC EFFICIENCY FOR THE SPECIFIED ASSUMPTIONS, SUPPLEMENTED BY AN ANALYSIS OF INVESTMENT (SENSITIVITY ANALYSIS TO CHANGES IN THE LEGAL AND ECONOMIC ENVIRONMENT)	80
7.1.	Subject, methodology and purpose of the analysis	80
7.2.	Assumptions	81
7.2.1.	Capital expenditure	81
7.2.2.	Discount rate	81
7.2.3.	Exchange rates	82
7.3.	Operating costs	82
7.3.1.	Fuel costs	83
7.3.2.	Spent nuclear fuel disposal costs	83
7.3.3.	Water replenishment costs	84
7.3.4.	Costs of salaries and employee benefits	84
7.3.5.	Property insurance costs	84
7.3.6.	Civil liability insurance for nuclear damage	84
7.3.7.	Property tax	85
7.3.8.	Renovation costs (unit maintenance)	85
7.3.9.	Future decommissioning costs	86
7.4.	LCOE results	87
7.5.	Sensitivity analysis	87
7.6.	Summary of the economic analysis	90
8.	ANALYSIS OF REQUIRED COMPETENCES FOR THE MANAGEMENT AND OPERATION OF A NUCLEAR POWER PLANT WITH CHARACTERISTICS SPECIFIC TO THE INVESTMENT OPTION (BASED ON THE REQUIRED COMPETENCIES RESULTING FROM RESEARCH TASK NO. 6)	91
8.1.	The most important elements of procedures for expanding or acquiring the competences required by the engineering and technical staff of modernised power plants and power units	92

8.2.	List of jobs with the highest employment in a nuclear power plant	92
8.3.	List of jobs with the highest employment in a coal-fired power plant	93
8.4.	List of jobs with the greatest shortage in nuclear power plants and the greatest surplus in coal-fired power plants	95
8.5.	Summary of information on selected jobs in a nuclear power plant	97
8.6.	Nuclear engineer	97
8.7.	Nuclear reactor operators	99
9.	RISK ANALYSIS REGARDING THE ORGANISATION AND SAFETY OF MODERNISATION AND OPERATION OF POWER UNITS WITH NUCLEAR REACTORS (BASED ON THE RESULTS OF RESEARCH TASK NO. 3, WHICH SETS OUT KEY REQUIREMENTS AND RECOMMENDATIONS CONCERNING NUCLEAR SAFETY FOR SELECTED SITES)	103
9.1.	Legal requirements	103
9.1.1.	General requirements for the location of a nuclear power plant	103
9.1.2.	General requirements for the design of nuclear reactors and nuclear power plants	104
9.2.	Kozienice power plant	107
9.2.1.	General characteristics of the Kozienice facility	107
9.2.2.	General characteristics of the AP1000 reactor	107
9.2.3.	Safety assessment of the retrofit – Technical aspects	109
9.2.4.	Safety assessment of the retrofit – Organisational aspect – emergency planning zones	110
9.3.	Summary	111
10.	IDENTIFICATION OF LEGAL AND REGULATORY BARRIERS TO THE INVESTMENT PROCESS	112
10.1.	Description of the procedural pathway for obtaining a construction permit for a nuclear facility	112
10.2.	Legal and legislative barriers to the investment process	117
10.2.1.	Dispersed and imprecise regulations	117
10.2.2.	Lack of experience among the administrative bodies involved in issuing decisions in the process of obtaining the necessary permits and authorisations	117
10.2.3.	Two separate assessment pathways for nuclear power plant construction projects and the lack of a separate derogation pathway for nuclear facilities	117
10.2.4.	No pathway for adaptating existing facilities	118
10.2.5.	Recommendations:	118
11.	INVESTMENT SCHEDULE	118
12.	SWOT ANALYSIS	120

LIST OF TABLES

Table 1 Electricity consumption in 2013–2023	11
Table 2 Average rate of change in energy production and consumption in selected periods between 2012–2023	13
Table 3 Combined cycle gas turbines in Capacity Market auctions	18
Table 4 Structure of electricity generation resources in 2034	19
Table 5 Required additional net available capacity in the National Power System [MW]	22
Table 6 Results of the optimisation of energy storage parameters for systems operating within power systems with the established structures	24
Table 7 Schedule for the modernisation of power units	27
Table 8 Schedule for decommissioning units	27
Table 9 Parameters of generating units	28
Table 10 Selected facilities planned to be connected to the transmission network, to SE Kozenice and neighbouring stations	29
Table 11 Comparison of the advantages and disadvantages of open-circuit cooling towers	33
Table 12 General characteristics of units B1-B11	44
Table 13 Comparative table of Generation III/III+ nuclear power plants	52
Table 14 Examples of dimensions of three-phase units	63
Table 15 Comparison of transformer manufacturing costs	63
Table 16 Forecast parameters of AP-1000 units at the Kozenice site	70
Table 17 Projected annual production figures for AP-1000 units at the Kozenice site	71
Table 18 Percentage distribution of estimated investment capital expenditure for the AP-1000 unit	73
Table 19 Classification of CAPEX estimation accuracy according to AACE International Recommended Practice	76
Table 20 Estimated construction costs for two AP-1000 class units at the Kozenice Power Plant	78
Table 21 Potential avoided costs based on hypothetical cost estimates	79
Table 22 Cost comparison	79
Table 23 Schedule of capital expenditure in the Greenfield variant, PLN million net	81
Table 24 Schedule of capital expenditure in the Brownfield variant, PLN million net	81
Table 25 Exchange rate forecast	82
Table 26 Sources of nuclear fuel prices	83
Table 27 List of the most common jobs in a nuclear power plant	93
Table 28 List of the most common jobs in a coal-fired power plant	94
Table 29 Summary of the most important positions with shortages and surpluses of jobs in coal-fired and nuclear power plants	95
Table 30 SWOT analysis	120

LIST OF FIGURES

Figure 1 Polish electricity market	10
Figure 2 Electricity consumption in Poland in 2009–2023	11
Figure 3 Structure of electricity consumption in Poland in 2023	12
Figure 4 Electricity production and consumption in Poland since 2012	13
Figure 5 Structure of electricity production in Poland since 2012	14
Figure 6 Installed capacity in the National Power System in recent years	15
Figure 7 Installed electrical capacity in Renewable Energy Sources	16
Figure 8 Schedule of decommissioning of coal-fired units participating in the central dispatch mechanism. Status at the end of the year.	17
Figure 9 Forecast annual electricity demand for 2024-2040	20
Figure 10 Average LOLE values [h/year] in 2025–2040	21
Figure 11 Average EENS values [GWh/year] in 2025–2040	21
Figure 12 Power demand in 2023 and power demand forecasts for 2035 and 2040	23
Figure 13 Forecast of generation source structures in 2035 and 2040	24
Figure 14 Section of the cooling water system diagram for 8 x 200 MW units	30
Figure 15 Site plan of the cooling system for units 9 and 10	31
Figure 16 Weir on the Vistula River	34
Figure 17 Layout of entrances to the Kozenice Power Plant	36
Figure 18 Road layout in the area of the Kozenice Power Plant	37
Figure 19 Diagram of state railway lines in the Kozenice Power Plant area	39
Figure 20 Diagram of railway lines on the premises of the Kozenice Power Plant	40
Figure 21 Sample soil test report	41
Figure 22 Flood risk area	42
Figure 23 Kozenice Power Station	46
Figure 24 Steam diagram of the AP-1000 unit	53
Figure 25 Steam diagram of the APR-1400 unit	54
Figure 26 Steam diagram of the APR-1600 unit	54
Figure 27 Location of the main power plant facilities	56
Figure 28 Building area of two nuclear units with AP-1000 reactors	57
Figure 29 Reactor building	59
Figure 30 Example block bay topology	64
Figure 31 Comparison of load (power) response rates in different types of grid-connected power plants	66
Figure 32 Layout of the main buildings of a nuclear power plant based on the AP-1000 reactor	67
Figure 33 Steam diagram of the AP-1000 unit with cooling system	69
Figure 34 Nuclear reactor availability factor in Europe for 2021–2023 according to the IAEA	70
Figure 35 CAPEX structure	71
Figure 36 Formula for determining LCoE	80
Figure 37 Nuclear fuel costs over the years	83
Figure 38 Unit capital costs	85
Figure 39 Unit operating costs	86
Figure 40 Annual operating costs for one AP-1000 unit	87
Figure 41 Comparison of Brownfield vs. Greenfield LCoE for both units	87
Figure 42 Structure of the calculated LCoE for the AP-1000 unit (Brownfield)	88
Figure 43 Sensitivity analysis results – capital expenditure and nuclear fuel price	89
Figure 44 Sensitivity analysis results – unit availability	89
Figure 45 Sensitivity analysis results – variable discount rate	90
Figure 46 Simplified diagram showing the process of obtaining a construction permit for a nuclear facility	116

LIST OF APPENDICES

1. Land use plan
2. Investment schedule
3. List of professions in nuclear and coal-fired power plants

1. Basic information about the project

The aim of the project is to develop a plan for decarbonising the national energy sector through modernisation using Generation III/III+ and IV nuclear reactors.

The ongoing transformation of the Polish power system reinforces the need to develop a coherent structure that ensures stability and security. The decarbonisation plan is being developed through seven research tasks and is intended to serve as a roadmap for future investment processes in the area of Coal-to-Nuclear policy. The project plans to launch a national Energy Transformation Cluster, which will provide organisational support for activities in the process of transforming national power plants and combined heat and power plants.

The project is being implemented by a consortium of five entities: the Silesian University of Technology, the Ministry of Climate and Environment, Energoprojekt-Katowice SA, the Institute of Nuclear Chemistry and Technology, and the Sobieski Institute Foundation. Funding for the project was obtained as part of the 6th competition of the National Centre for Research and Development "Gospostrateg".

2. Market analysis of investment demand

The main objective of this project is to investigate the possibility of replacing coal-based sources of electricity generation with nuclear energy from Generation III/III+ reactors. This solution fits perfectly into the pan-European decarbonisation plan and the pursuit of a zero-emission European electricity system.

This chapter presents the current situation in the electricity generation sector in Poland and its projected development over the next few decades, taking into account other projects, including planned nuclear power plants and new renewable energy sources, developed on the basis of published government plans, strategic documents and analyses by the transmission system operator.

2.1. Current characteristics of the electricity market in Poland

The Polish electricity market operates on the basis of the Energy Law Act of 10 April 1997, as amended. The institution regulating the legal aspects of the market's operation is the Energy Regulatory Office (*Urząd Regulacji Energetyki* - URE), the transmission system operator is Polskie Sieci Elektroenergetyczne (PSE SA), and electricity trading is possible through the Polish Power Exchange (*Towarową Giełdę Energii* - TGE).

In 2024, the Polish electricity market was characterised by the following figures:



Electricity production
○ 166.99 TWh

Peak demand
○ 28.66 GW

Total installed capacity
○ 72.8 GW

Average wholesale energy price
○ PLN 418/MWh

Data source: ARE, PSE, TGE.

Figure 1 Polish electricity market

2.1.1. Structure of electricity demand and supply

The required level of electricity production results from the demand for electricity within a given power system. Over the last dozen or so years, there has been an upward trend in electricity consumption in Poland. However, at the turn of 2019 and 2020, as a result of the outbreak of the global COVID-19 pandemic, a significant drop in electricity consumption was observed. The lockdowns announced by the government in 2020-2021 resulted in reduced electricity consumption, mainly in the industrial and construction sectors and among small consumers. It was not until 2022 that electricity consumption returned to the level seen before the outbreak of the COVID-19 pandemic.

Detailed data on electricity consumption by individual sectors over the last dozen or so years is presented in the table and graph below. Data for 2024 has not yet been published and will only be available at the end of 2025.

Table 1 Electricity consumption in 2013-2023

Sectors, TWh	2013	2014	2015	2016	2017	2018	2019	2020	2021	2022	2023
Own consumption of power plants and and professional power plants and heat and power plants ¹	14.1	13.5	13.4	14	14.3	14	13.8	12.5	14.20	13.88	12.24
Own consumption of professional heating plants	0.3	0.3	0.2	0.2	0.2	0.2	0.2	0.2	0.23	0.16	0.19
Mining and extraction	8.8	8.7	8.7	8.5	8.3	8.3	8.2	7.9	8.16	7.89	7.85
Industry and construction	47.9	48.2	50	52.1	55	57.8	57.2	55.8	58.86	57.62	54.14
Water supply; sewage and waste management waste management	2.6	2.7	2.7	2.9	3	3.1	3.1	3.1	3.32	3.28	3.27
Transport	4.1	4	4.3	4.6	5.2	5.6	5.6	5.3	5.72	5.92	6.40
Small business sector customers	68.6	70.9	71	73.9	73.1	74	72.9	72.4	73.51	74.71	71.07
Total consumption²	146.4	148.1	150.3	156.2	159.0	162.9	161.0	157.1	164.0	163.5	155.2
Consumption dynamics	100.3	101.2	101.5	103.9	101.8	102.5%	98.8	97.6	104.4%	99.7%	94.9%
Average growth rate from period	100.6%										

Source: own study based on: Fuel and energy carrier consumption (Central Statistical Office)

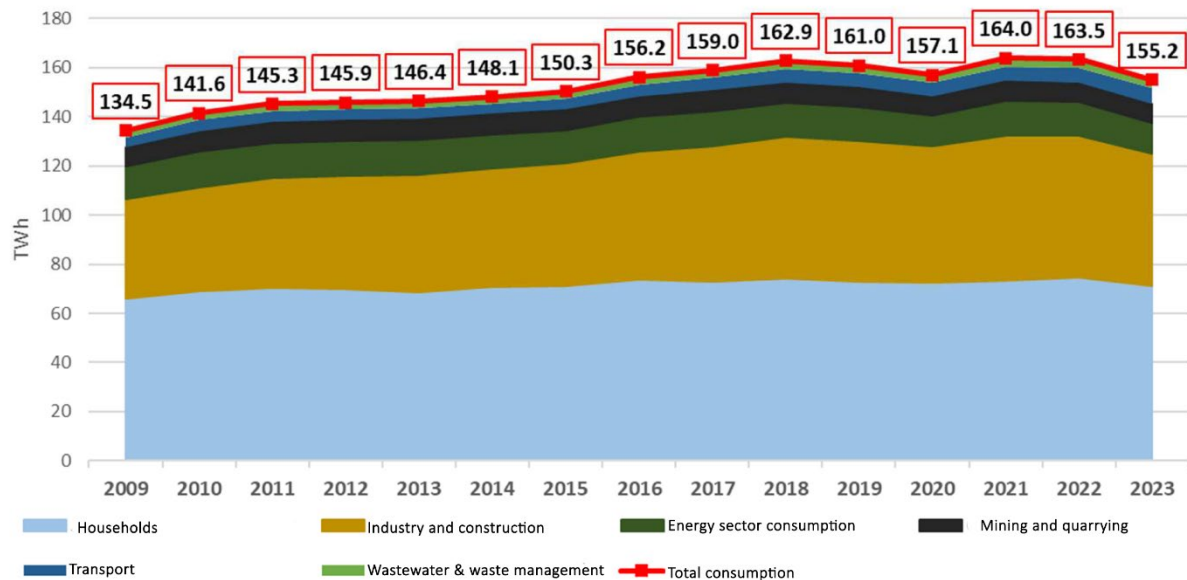

Figure 2 Electricity consumption in Poland in 2009-2023

Source: own study based on: FUEL AND ENERGY CONSUMPTION (Central Statistical Office)

The progressive increase in electricity consumption is offset by energy efficiency measures, hence the decline in consumption in 2023 and the slowdown in growth observed since 2009.

¹ together with commercial heating boilers

² does not include direct consumption for heating and lighting in entities classified under section D (PKD2007)

Looking at the structure of energy consumption, the small consumer sector occupies a dominant position (45.8% in 2023). Industry and construction also consume large amounts of energy (34.9% in 2023). Approximately 7.9% of total consumption is accounted for by power plants and combined heat and power plants. The mining and quarrying sector consumes slightly more than 5% of energy. The least energy is consumed by the transport and water supply sector and waste management: 4.1% and 2% respectively.

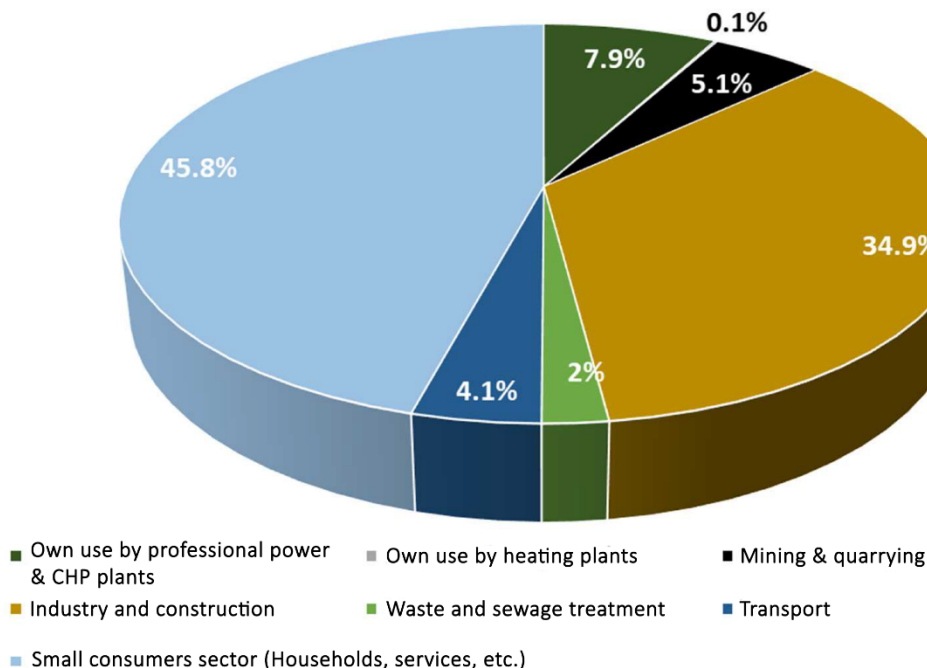

Figure 3 Structure of electricity consumption in Poland in 2023

Source: own study based on: Fuel and energy carrier consumption in 2023 (Central Statistical Office)

The decline in electricity consumption in 2019–2021 also translated into lower electricity production from domestic generation sources. Over the last dozen or so years, electricity production in Poland has shown a slight upward trend despite global events. Depending on the length of the analysed time period, it takes the following average annual values:

- 2022–2024 (last 3 years) – average increase of 2.8%
- 2019–2023 (5 years) – average increase of 0.1%
- 2014–2023 (10 years) – average growth of 0.2%

Domestic electricity production in 2024 amounted to 166.99 TWh and was over 2% higher than in 2023, while consumption increased by 0.9%. Thus, the interconnection balance amounted to approximately 2 TWh of imports. The chart below shows the changes in electricity demand and production in Poland since 2012, according to data from the transmission system operator PSE. The electricity consumption presented by PSE is higher than the consumption reported by the Central Statistical Office (*Główny Urząd Statystyczny* - GUS), which may be due, among other things, to the fact that some electricity consumers do not report their consumption to GUS.

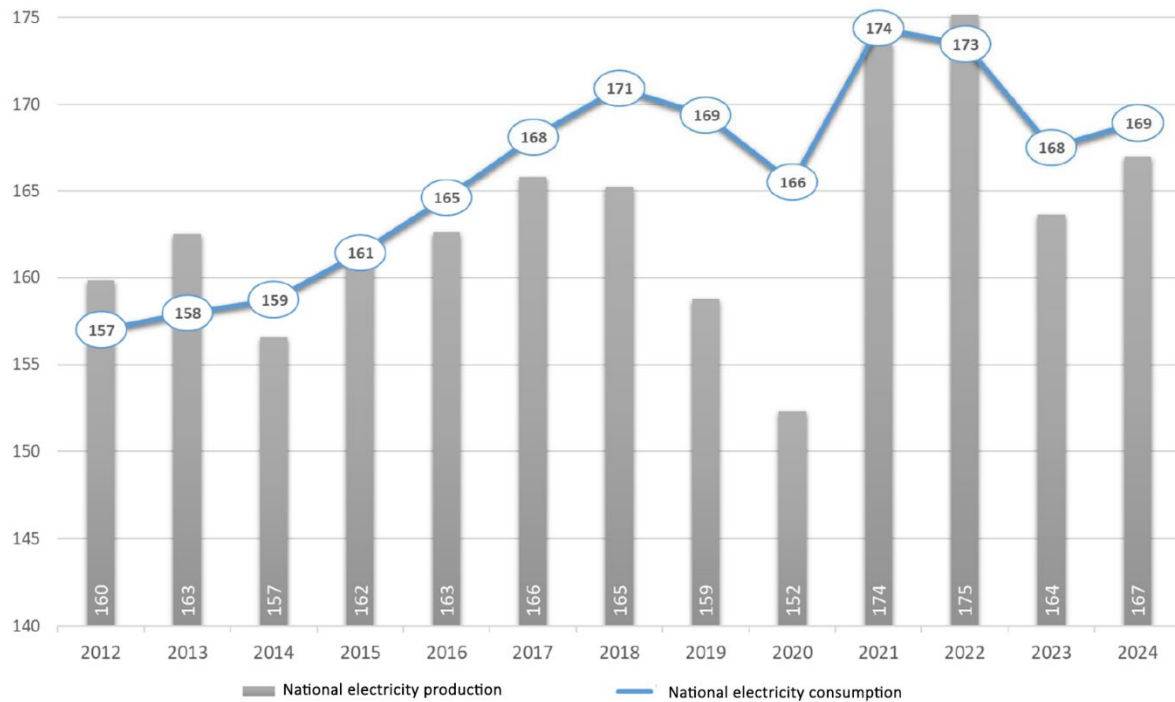

Figure 4 Electricity production and consumption in Poland since 2012

Source: own study based on PSE data

The table below presents the dynamics of changes in three time intervals, which shows that energy production in the long term has been growing with considerable fluctuation in recent years. Historical energy consumption grew until the pandemic, and after a large increase and decrease in recent years, it is now showing an upward trend again.

Table 2 Average rate of change in energy production and consumption in selected periods between 2012–2023

PSE data	Last 3 years	Last 5 years	10 years
Energy production	-1.2	+1.3%	+0.8%
Energy consumption	-1.0	+/-0%	+0.7

Hard coal and lignite combustion sources account for the largest share of electricity production in Poland. However, year on year, there has been a noticeable decline in the share of these sources due to increased production from renewable energy sources. In addition, new natural gas-fired units, replacing coal-fired sources, have also increased their share in electricity production in recent years. Hydroelectric power plants have a stable share of electricity generation, similar to industrial combined heat and power plants.

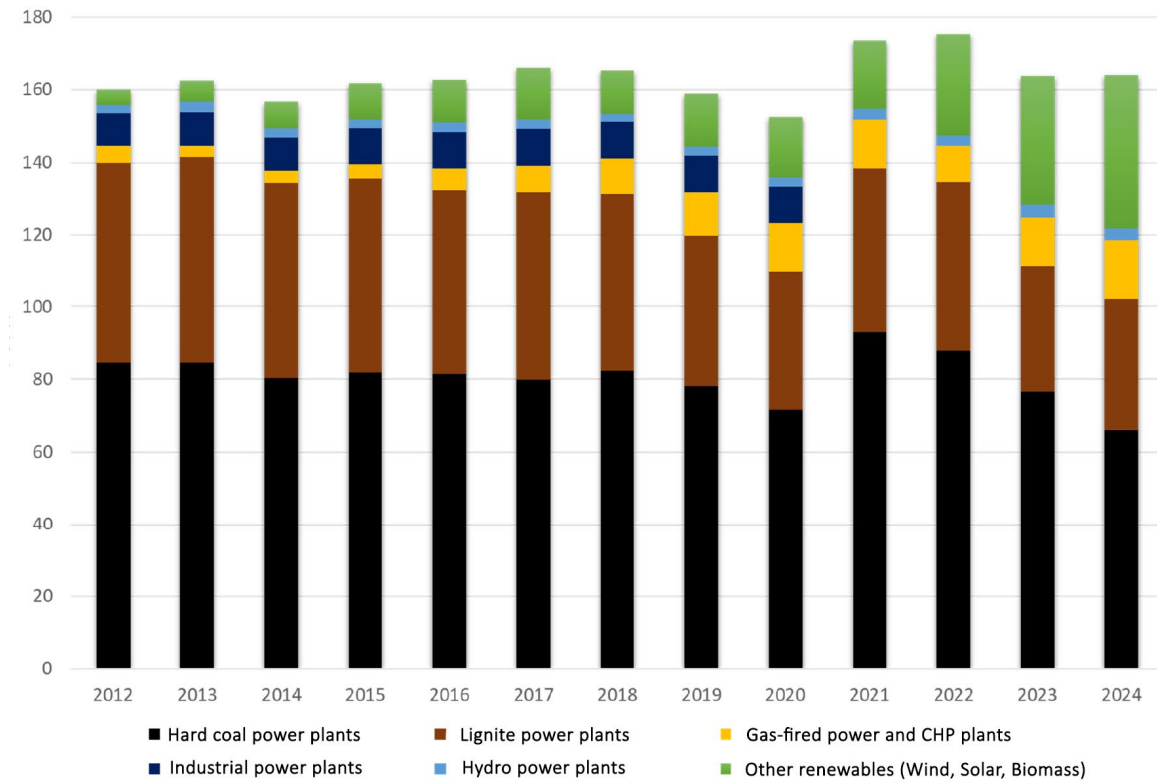

Figure 5 Structure of electricity production in Poland since 2012

Source: own study based on PSE data

2.1.2. Structure of installed capacity in the National Power System

Currently, the Polish energy mix is based predominantly on coal, both hard coal and lignite. Coal fuel is burned primarily in system condensing units, as well as in industrial and municipal combined heat and power plants (cogeneration sources). Changes in installed capacity in recent years are mainly related to the growth of Renewable Energy Sources. The chart below shows changes in installed capacity in the National Power System in recent years.

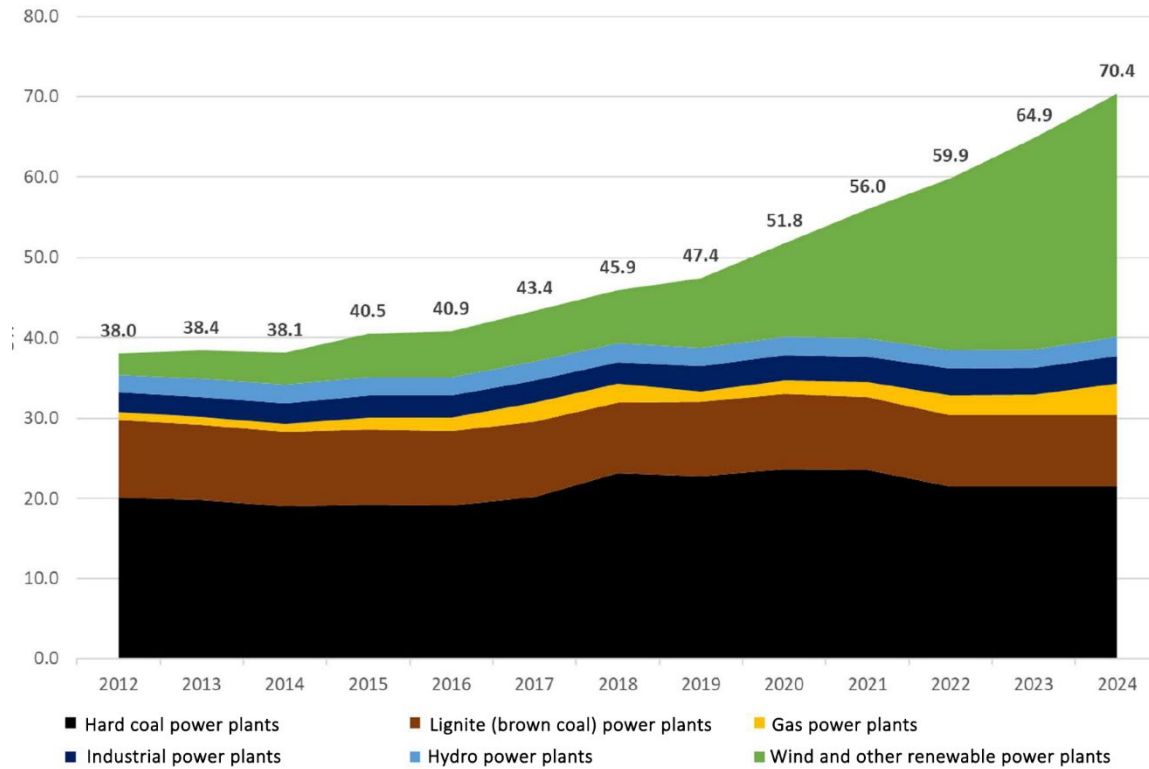

Figure 6 Installed capacity in the National Power System in recent years

Source: Own study based on data from Energy Regulatory Office (Urząd Regulacji Energetyki - URE) and the Energy Market Agency (Agencja Rynku Energii S.A. - ARE) (since 2019)

In the case of new conventional generation sources, new gas-and-steam units have been connected to the system in recent years: in Włocławek – 485 MW (2017), Płock – 630 MW (2018), Stalowa Wola – 467 MW (2019) and EC Żerań – 497 MW (2021). In addition, in 2024, units in Dolna Odra with a total capacity of 1,400 MW were put into operation.

The most recent non-gas conventional investments include two units in Opole with a total capacity of 1,800 MW, commissioned in 2019, and a 900 MW unit in Jaworzno, commissioned a few years later.

Despite the appearance of the above-mentioned new units in the system, due to the age of the remaining units operating in the National Power System, the Polish power industry is not among the youngest. The majority of them are between 40 and 50 years old, and several units are already over 50 years old. The average age of generating units in Poland is over 37 years.

In terms of renewable energy sources in Poland, electricity is obtained from wind, water resources, solid biomass, biogas and liquid biofuels, as well as solar radiation. Geothermal resources are mainly used in heating installations (heating sector).

In recent years, there has been rapid development in solar energy sources, particularly in the prosumer sector – domestic photovoltaic installations.

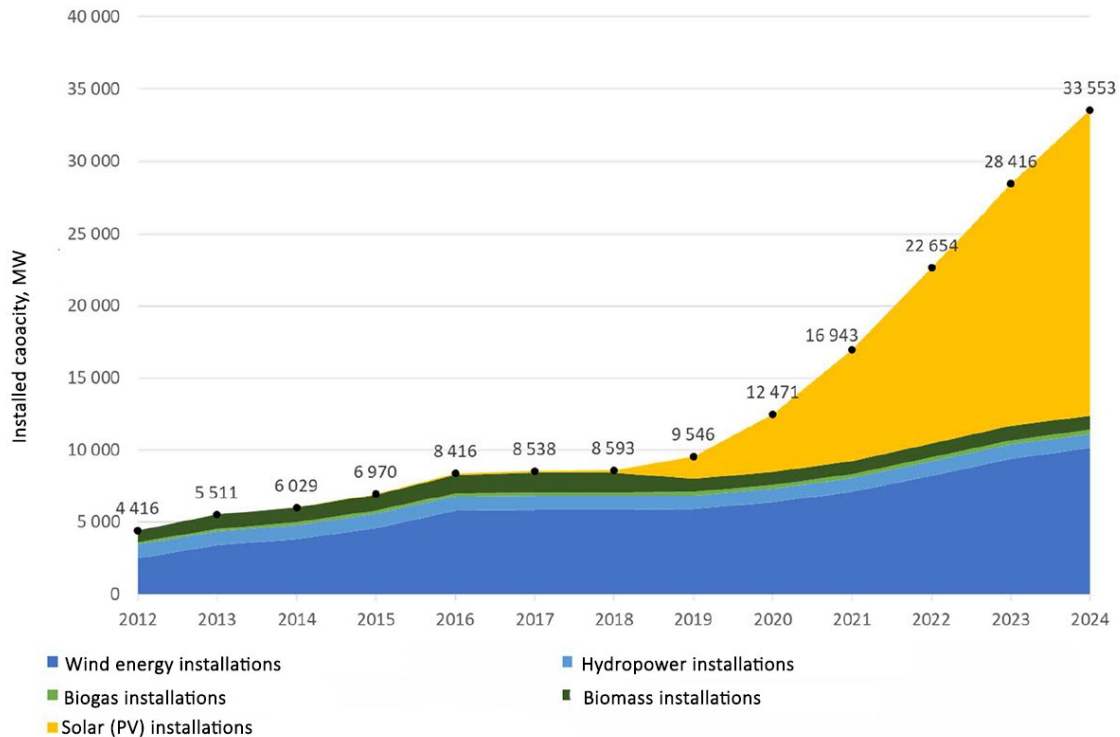

Figure 7 Installed electrical capacity in Renewable Energy Sources

Source: Own study based on data from the Energy Regulatory Office (URE) and the Energy Market Agency (ARE) (since 2019)

The installed electrical capacity of renewable energy sources in Poland at the end of 2024 exceeded 32.5 GW (according to ARE). Solar sources accounted for the largest share of installed capacity – over 19 GW. Wind installations were the next largest, with over 10 GW.

2.2. Forecast for the development of the electricity market in Poland

The following market development forecast has been prepared on the basis of the Development Plan for Meeting Current and Future Electricity Demand³ by PSE and other publicly available reports on the functioning of the electricity market, as well as EPK's knowledge gained from many years of activity on the electricity market.

The forecasts presented are intended to indicate the conditions under which the project in question can be implemented and how the energy transition process in Poland may proceed.

2.2.1. Forecast of installed capacity

Over the years, Poland's energy mix will evolve in line with the ongoing decarbonisation of the power generation sector, accompanied by significant growth in renewable energy sources. Most coal-fired power stations in Poland are ageing, and their modernisation makes no economic sense given the declining share of coal in the energy mix. Furthermore, coal-fired units have the highest unit carbon dioxide emissions (kgCO₂/kWh), meaning they cannot be financed by, for example, the capacity market (at present, coal-fired units could only participate in capacity market auctions until 2025) or the financial market (investment loans), and at the same time they incur high CO₂ emission costs. Taxonomy in the broad sense also excludes investments in this type of energy source.

³ Development plan for meeting current and future electricity demand for the years 2025–2034; PSE; December 2024. <https://www.pse.pl/-/projekt-nowego-planu-rozwoju-sieci-przesylowej-na-lata-2025-2034-uzgodniony>

The schedule for the decommissioning of coal-fired power units based on the PSE report⁴(broken down into hard coal and lignite) is presented below – these capacities will need to be replaced in the future in order to maintain an adequate level of available capacity in the system.

The diagram shows the blocks of the Kozenice power plant, which is considered in this report in terms of its use for the construction of Generation III/III+ reactors. The decommissioning dates are taken from the consolidated report of ENEA S.A. for the third quarter of 2024.

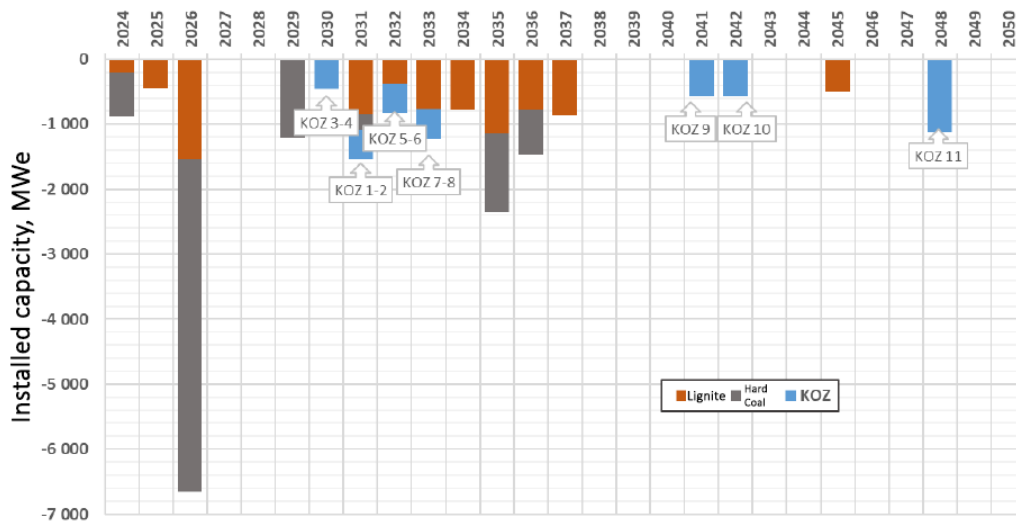

Figure 8 Schedule of decommissioning of coal-fired units participating in the central dispatch mechanism. Status at the end of the year.

Source: Own study based on PSE data

In terms of new capacity, the plan includes the construction of new combined cycle gas turbines, which were submitted for **auctions on the Capacity Market**. The last auction took place in December 2024 for the 2029 delivery year. The table below lists the new gas-fired combined cycle units that won the Power Market auctions, some of which are currently at an advanced stage of construction.

⁴ Development plan for meeting current and future electricity demand for the years 2025–2034; PSE; December 2024. <https://www.pse.pl/-/projekt-nowego-planu-rozwoju-sieci-przesylowej-na-lata-2025-2034-uzgodniony>

Table 3 Combined cycle gas turbines in Capacity Market auctions

No.	Name of power supplier	Location	Year of supply	Capacity of power obligation [MW]	Duration of capacity obligation [years]
1	PGE Polska Grupa Energetyczna S.A.	Dolna Odra	2024	667.6	17
2	PGE Polska Grupa Energetyczna S.A.	Dolna Odra	2024	667.6	17
3	CCGT Grudziądz sp. z o.o.	Grudziądz	2026	518.4	17
4	PAK CCGT Ltd.	Adamów	2026	493.0	17
5	CCGT Ostrołęka sp. z o.o.	Ostrołęka	2026	696.0	17
6	PGE Polska Grupa Energetyczna S.A.	Rybnik	2027	794.6	17

Another source that could replace coal in the energy mix is nuclear power plants. The current strategy for the development of nuclear energy in Poland is described in **the Polish Nuclear Power Programme** published in October 2020. It envisages the construction of six nuclear units every two years, starting in 2033. In total, two nuclear power plants will be built in two locations, each with three units. Currently, it is assumed that the first power plant will be built in Lubiatowo-Kopalín on the Baltic Sea and will use Westinghouse AP-1000 reactors. The location of the second power plant is not yet known, but various locations are being considered, including Konin, Bełchatów, Połaniec and Kozienice.

The Development Plan for Meeting Current and Future Electricity Demand for 2025-2034, prepared by PSE, also provides for smaller nuclear units using SMR (small modular reactor) technology. According to the PSE report, information obtained from professional electricity producers through a survey was taken into account when determining the future generation structure. Plans for the development of offshore wind farms and nuclear energy, as specified in strategic documents, were also taken into account. Information on the results of RES auctions, as well as major national support programmes dedicated to prosumer sources and the results of concluded capacity auctions, was taken into account.

PSE has prepared a projected electricity generation structure in two scenarios, the SST (*Scenariusz Swobodnej Transformacji* - Free Transformation Scenario) and SDT (*Scenariusz Dynamicznej Transformacji* - Dynamic Transformation Scenario), which differ mainly in terms of the installed capacity of renewable energy sources and energy storage facilities. The table below presents the results of PSE's analyses.

Table 4 Structure of electricity generation resources in 2034

Type of power resource	SST scenario Net capacity [MW]	SDT scenario Net capacity [MW]
Lignite	4,401	
Hard coal	6,317	
Hard coal - peak sources	2,277	
Natural gas	10,772	
Biomass and biogas	2,830	
Large nuclear power plants	1,146	2,292
SMR	560	840
Hydroelectric power	1,250	
Pumped storage power plants	2,462	
Photovoltaics	36,000	45,000
Onshore wind farms	16,940	19,362
Offshore wind farms	10,900	11,885
Energy storage facilities	3,750	15,207
Combined heat and power plants	5,217	

Source: Transmission network development plan for 2025–2034, PSE

2.2.2. PSE electricity demand forecast

The long-term forecast of energy demand in the National Power System presented in this section was prepared by PSE⁵ taking into account:

- historical trends and the forecast for final energy consumption.
- macro factors affecting the structure of energy consumption in the household, transport, industry and services sectors,
- changes in the area of energy efficiency,
- forecasts of Gross Domestic Product growth in individual sectors,
- technological and consumer changes, as well as changes resulting from EU directives regarding Poland's achievement of the required RES target in final energy consumption,
- anticipated structural changes in final energy consumption, i.e. an increase in the number of electric vehicles, heat pumps and fuel cells, among other things.

The prepared forecast assumes two scenarios that address the adopted path of development of the PSE environment. The first is a scenario of gradual transformation, and the second is one of dynamic transformation, which assumes a significant increase in energy demand. These scenarios are illustrated in the charts below. Both scenarios assume an increase in electricity demand in the future.

⁵ Development plan for meeting current and future electricity demand for 2025-2034; PSE; December 2024.
<https://www.pse.pl/-/projekt-nowego-planu-rozwoju-sieci-przesylowej-na-lata-2025-2034-uzgodniony>

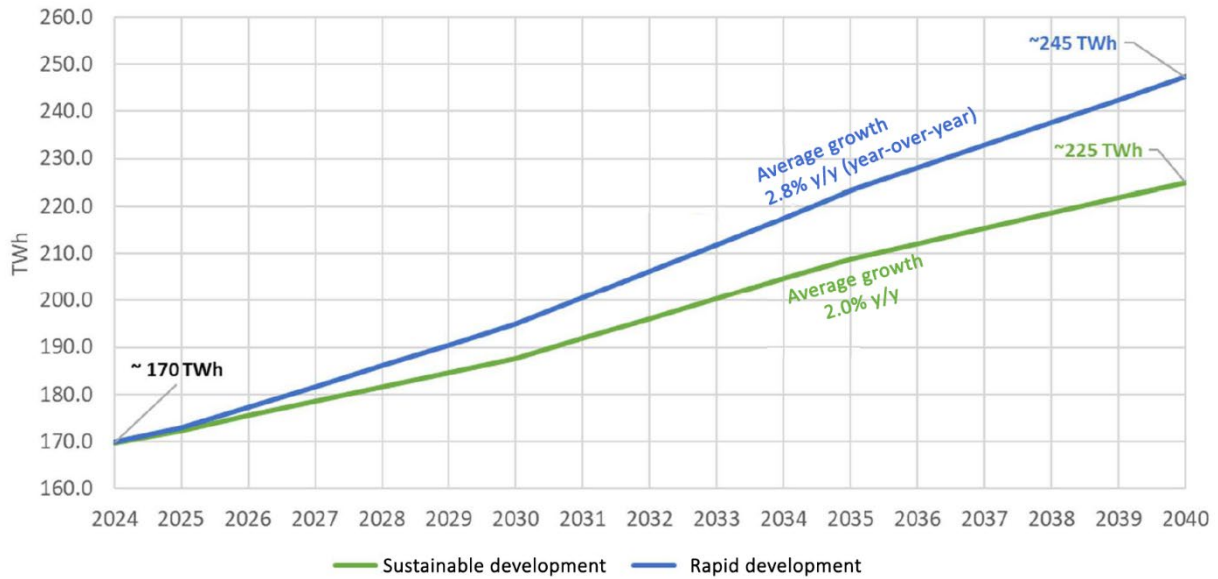

Figure 9 Forecast annual electricity demand in 2024–2040

Source: Own study based on PSE data

2.2.3. Analysis of the adequacy of generation sources

Based on the presented mix of installed capacity and projected electricity demand, the PSE Report presents the results of analyses of the sufficiency of generation sources and the security of the power system. Two power system reliability indicators, LoLE and EENS, were used for the assessment.

The first indicator, LoLE (Loss of Load Expectation), indicates the average number of hours per year during which the power system is likely to be unable to meet electricity demand due to a shortage of (available) power in the system. This indicator helps the transmission system operator (PSE) assess whether the national power system is sufficiently reliable. The safety standard assumes LoLE values of no more than 3 hours per year (average for the climate years 1982-2019).

At the international level, LoLE is a standard used in reports prepared by organisations such as ENTSO-E (European Network of Transmission System Operators) as part of regional and pan-European analyses, such as the Mid-term Adequacy Forecast (MAF). It enables the comparison of the reliability of power systems in different countries and the identification of potential threats in the context of the energy balance. LoLE is also a key element in analyses related to the implementation of new RES sources, such as offshore wind farms, where the variability of energy production requires precise estimates of demand and capacity availability.

The second indicator, EENS (Expected Energy Not Served), indicates the amount of electricity (in GWh) that will not be delivered to consumers as a result of power shortages in the power system. This is the estimated amount of energy whose supply may be interrupted during the year due to insufficient availability of generation sources or transmission constraints.

The average LoLE and EENS values determined in the PSE Report ⁶are presented below.

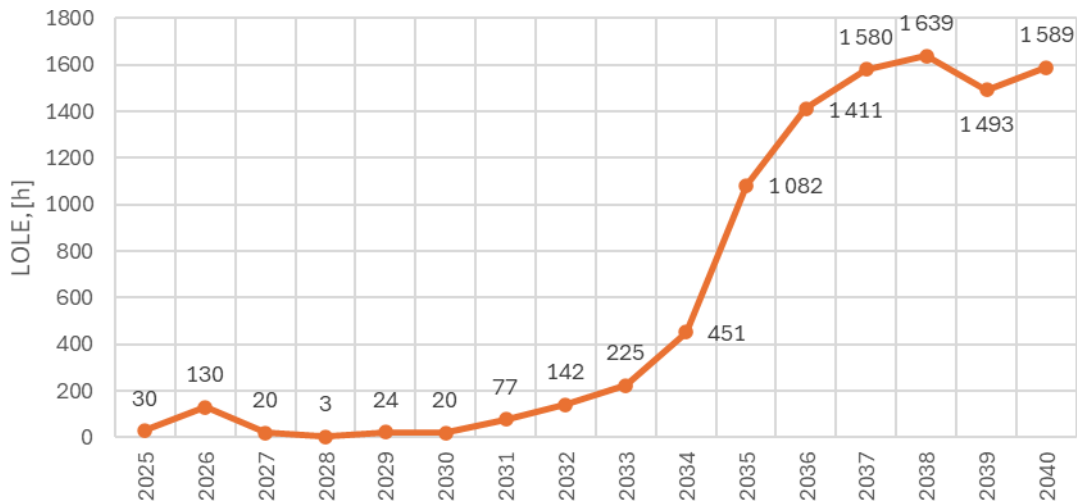

Figure 10 Average LoLE values [h/year] in 2025–2040

Source: Own study based on the PSE Report

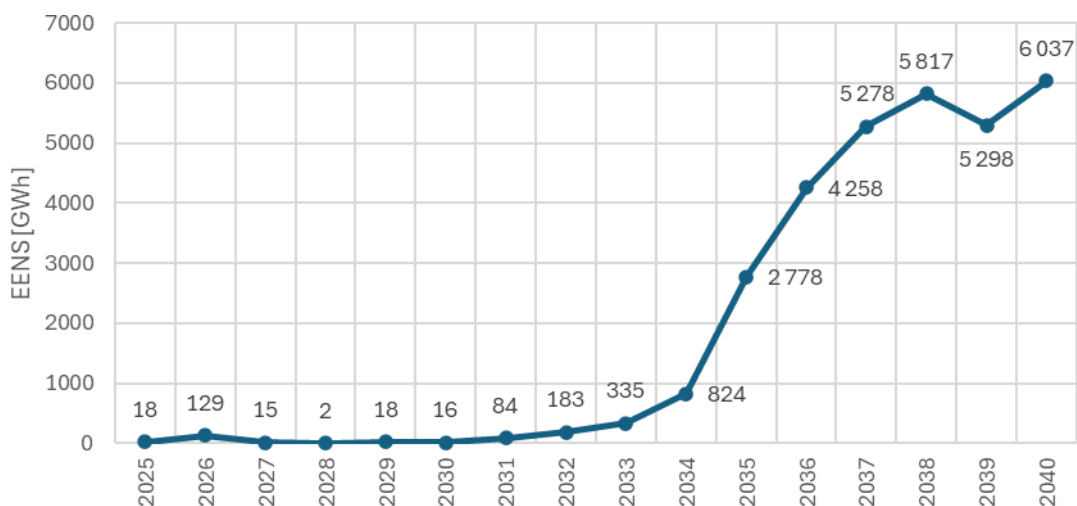

Figure 11 Average EENS values [GWh/year] in 2025–2040

Source: Own study based on the PSE Report

Both indicators show a noticeable increase as early as 2026, followed by a decline and another increase after 2030, with the indicators reaching several dozen times higher than the initial values in the period 2035–2040. Over the entire period under review, the LoLE indicator does not exceed the assumed 3 hours per year in only one year.

2.2.4. Required additional available capacity

The PSE Report presents a solution aimed at keeping the presented indicators as low as possible (including LoLE<3h). The amount of additional available capacity that would need to be added in a given year to ensure the security of the energy system has been estimated.

⁶ Development plan for meeting current and future electricity demand for 2025-2034; PSE; December 2024.
<https://www.pse.pl/-/projekt-nowego-planu-rozwoju-sieci-przesylowej-na-lata-2025-2034-uzgodniony>

Table 5 Required additional net available capacity in the National Power System [MW]

2025	2026	2027	2028	2029	2030	2031	2032	2033	2034	2035	2036	2037	2038	2039	2040
1,400	3,400	1,600	200	1,600	1,600	3,200	4,200	5,200	6,800	9,600	11,200	12,200	12,800	12,800	13,600

Source: Own study based on the PSE Report

As early as 2026, an additional 3.4 GWe of net available capacity will be required, and after 2030 this figure will continue to rise. By 2040, it will be four times higher (13.6 GW). As the authors of the Report mention, it should be borne in mind that the assumed additional capacity may be higher depending on:

- the pace of energy transition in the country – faster growth in electricity demand,
- climatic conditions in future years – harsher winters, less sunny summers,
- changes to the dates for decommissioning conventional units – earlier than assumed in the report,
- changes to the dates for commissioning new capacity – later than assumed in the report.

In addition, the authors of the report presented potential sources of additional available capacity, which may include:

- new gas-fired power plants (in addition to those contracted on the capacity market),
- extension of the operation of existing coal-fired units (including extension of the capacity market for them after 2025),
- new energy storage facilities (using various technologies) with accompanying new RES sources,
- new biomass and biogas power plants,
- new hydrogen and alternative fuel technologies,
- additional energy import opportunities and growth in demand side response (DSR) services. Most of the solutions presented, apart from conventional units, are unlikely to ensure stable coverage of demand, especially in terms of high volume and continuity of supply.

2.3. Selection of optimal system structures

Based on the presented PSE forecast of demand growth and the energy mix, a team of scientists from the Silesian University of Technology in Gliwice performed a model optimisation of the power system structure in Poland.

First, for both PSE scenarios of electricity demand growth, an estimate of hourly demand changes for 2035 and 2040 was made. The figure below shows a comparison of the curves for different years, broken down into both scenarios.

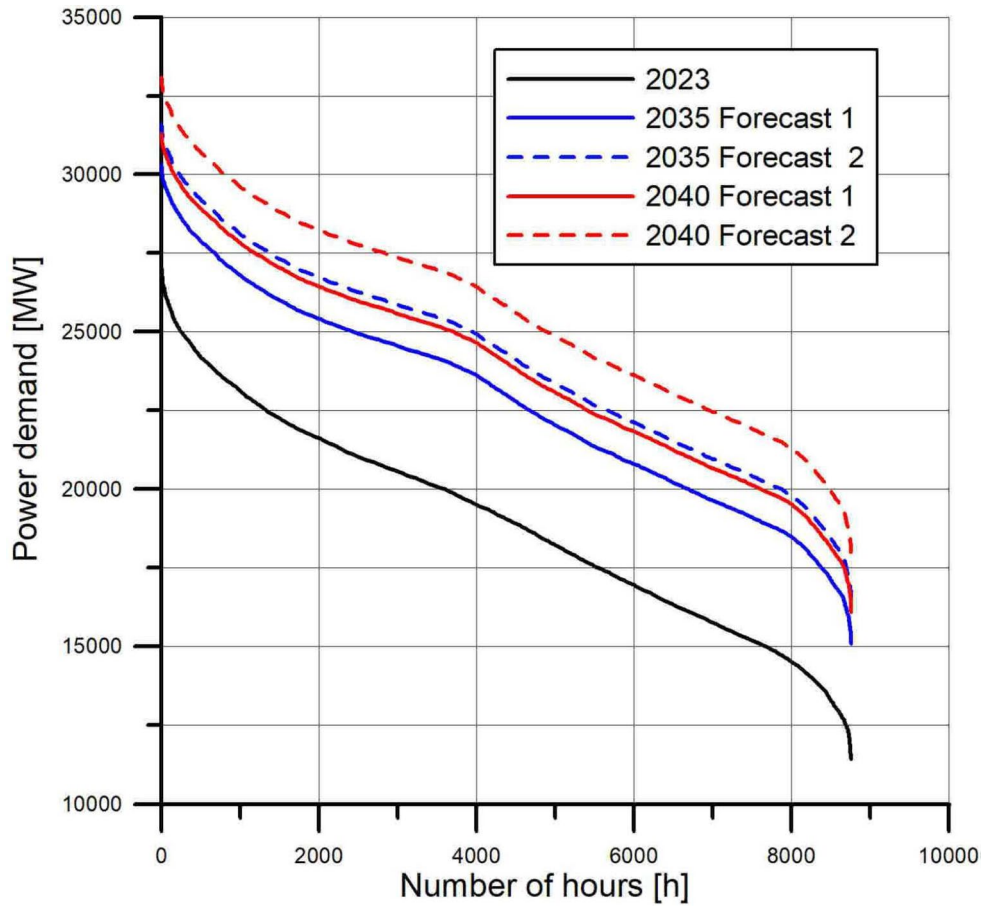

Figure 12 Power demand in 2023 and power demand forecasts for 2035 and 2040

Source: Presentation - Nuclear investments and national energy security; A. Rusin, A. Wojaczek, PŚ

In the second step, the projected energy mix was determined in two cases, with greater and lesser development of nuclear energy (understood as large-scale units and SMRs). It was also assumed that the RES capacity projected for 2034 from the dynamic transformation scenario would be achieved in 2040. Furthermore, no coal-fired units were assumed in the mix after 2040, and it was assumed that no new gas-fired units would be added. The energy mix does not take energy storage into account at this stage, as the required power and capacity of energy storage facilities was the result of this optimisation.

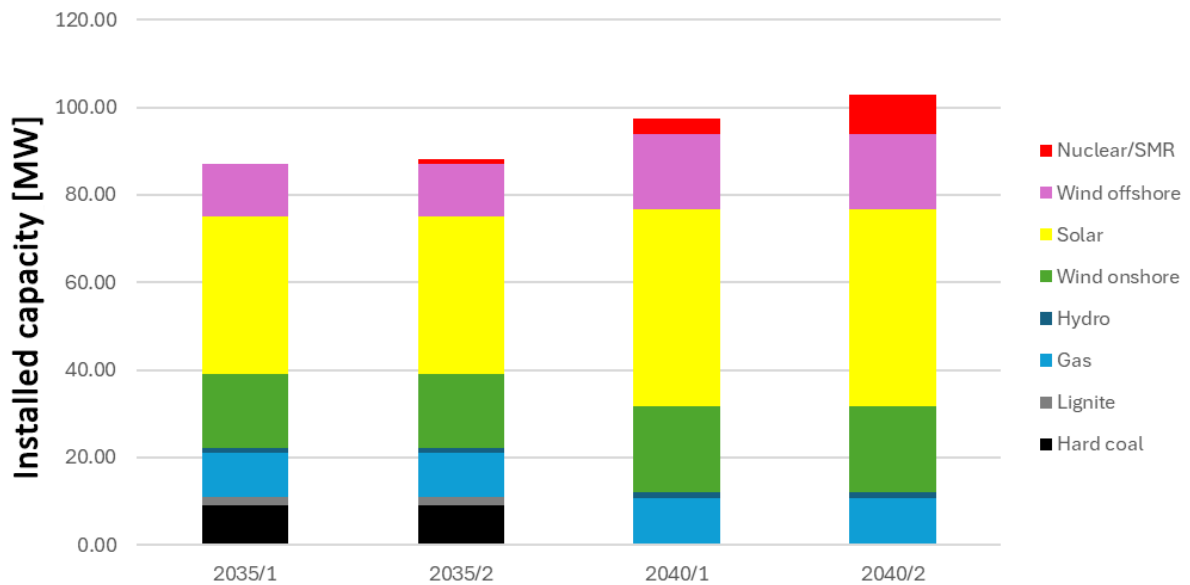

Figure 13 Forecast of generation source structures in 2035 and 2040

Source: Own study based on the presentation: Nuclear investments and national energy security; A. Rusin, A. Wojaczek, PŚ

For the preliminary structure of power sources in the system and the characteristics of power demand in a given year, the optimal capacity and power of energy storage facilities were selected so that the energy system supported by these storage facilities would ensure the required reliability of energy supply. This required level of reliability was adopted as the limit value of the LoLE indicator, amounting to 3 hours/year.

Table 6 Results of the optimisation of energy storage parameters for systems operating within power systems with the established structures

Year/system	Demand forecast	LoLE initial [h]	Storage capacity [MWh]	Warehouse capacity [MW]	Number of hours of empty storage [h]	Number of hours of full storage [h]	Final LOLE [h]	
2035/1	Forecast 1	30.5	7,300	1400	65	7791	3.00	
2035/2	Forecast 2	156.1	16,400	2900	104	7,199	2.99	
2035/2	Forecast 1	42.4	8700	1600	72	7696	2.99	
2040/1	Forecast 2	811.6	220,000	5600	5	4822	3.22	
2040/2	Forecast 1	3.7	Unnecessary storage					
2040/2	Forecast 2	90.5	11,100	2000	72	7607	3.03	

Source: Own study based on the presentation: Nuclear investments and national energy security; A. Rusin, A. Wojaczek, PŚ

In conclusion, maintaining the reliability of the National Power System at an appropriate level requires the presence of a sufficient number of stable energy sources in the system to meet demand, which in the current situation cannot be fully replaced by wind and solar sources. Nuclear power plants supplemented by gas-fired units could fulfil this role. Energy storage facilities with adequate capacity and power must play an important role in stabilising a system with a high share of renewable energy sources.

Until the aforementioned new energy sources and a sufficient number of energy storage facilities are built and commissioned, only existing coal-fired units and new gas-fired units can ensure the reliable operation of the energy system.

2.4. Summary of the energy market analysis

- When analysing the current situation on the electricity market, it should be assumed that demand for electricity will grow over the next few decades. Consequently, electricity production should also grow or remain at a level that allows the system to be balanced in conjunction with, for example, energy imports or demand reduction.
- The presented schedule for decommissioning coal-fired units indicates a significant decline in coal-based power generation in the coming years. In Koźienice, 200 MW units are expected to be decommissioned in the early 2030s, and 500 MW units in the early 2040s. Most coal-fired power plants are already advanced in age and it is difficult to extend their operation. On the other hand, all planned new gas units are unlikely to replace coal-fired sources on a 1:1 basis.
- Given the current situation in the electricity generation sector and the direction set by EU countries towards a zero-emission system, it seems reasonable to develop new nuclear-based investments. On the other hand, gas-fired units with lower CO₂ emissions are transitional on the way to zero-emission electricity production, which will also be enforced by the EU (e.g. through investment financing mechanisms – exclusion of fossil fuels, taxonomy, carbon footprint, requirements regarding reporting on sustainable development, in particular the CSRD directive, etc.).
- The projected significant growth in renewable energy sources (over 30 GW in PV by 2034 according to PSE forecasts) and their "priority" in electricity sales may hinder the operation of large conventional units by limiting their use in the market. Even despite the assumed development of electricity storage in the system, controllable units may be required to ensure energy security on the generation side, especially in Koźienice, which secures the central part of Poland.
- According to the SE optimisation carried out by the Silesian University of Technology, without stable generation sources (such as nuclear power), the power system in Poland will need very high-capacity storage facilities (even over 220 GWh) with a large number of cycles (which affects the service life of the storage facilities).
- In turn, according to PSE analyses, without additional available capacity, it may not be possible to ensure an adequate level of security for the power system, or other mechanisms (DSR, emergency energy imports) may be activated, which may lead to an increase in electricity costs or, in a critical situation, to a blackout.

3. Detailed diagnosis of the technical condition of the existing infrastructure of the facility in terms of its potential use for the needs of a nuclear power plant, including the infrastructure necessary for the operation of the power plant, i.e. transmission networks, road and rail infrastructure, external and internal water sources

3.1. General information

The Koźienice Power Plant is the second largest coal-fired power plant in Poland, and the largest among power plants using hard coal. The power plant is located in Świerże Górne near Koźienice, in the Mazowieckie Province.

3.1.1. Existing generating units

There are currently 11 units operating at the Koźienice Power Plant ⁷

- Units 1-8 with a capacity of 200 MW
- Units 9-10 with a capacity of 500 MW
- Unit 11 with a capacity of 1075 MW.

The 200 MW units were commissioned in the following years:

- Unit no. 1 – 1972
- Units 2, 3, 4, 5 – 1973,
- Units 6 and 7 – 1974
- Unit no. 8 – 1975.

The 500 MW units were commissioned in the following years:

- Unit no. 9 – 1978,
- Unit no. 10 – 1979.

The 1075 MW unit was commissioned in 2017.

In addition, the power plant is equipped with a diesel-powered generator with an electrical output of 0.72 MW_e. In addition to electrical power, the power plant also generates heat in a combined cycle system, in which steam is supplied from steam turbine bleed valves through reduction and cooling stations to three heating units with a capacity of 35 MW each. The achievable thermal power of the power plant is 266 MW_t.

Units 1-10 use an open condenser cooling system with water taken from the Vistula River. Unit 11 has a closed cooling system using a cooling tower, which has a minor impact on water intake from the river. Water is taken exclusively for the purpose of replenishing the unit's systems at a rate of approximately 0.7 m³/s.

⁷ <https://elektrowniakozienice.com/o-elektrowni/dane>, https://pl.wikipedia.org/wiki/Enea_Wytwarzanie

The units are being systematically modernised according to the following schedule:

Table 7 Unit modernisation schedule

List of planned investments at Kozenice Power Station S.A. up to 2030 for the option to construct a new 1000 MW unit

Specification	2009	2010	2011	2012	2013	2014	2015	2016	2017	2018	2019	2020	2021	2022	2023	2024	2025	2026	2027	2028	2029	2030
Decommissioning of existing units																						
Unit No. 1																						
Unit No. 2																						
Unit No. 3																						
Unit No. 4																						
Unit No. 5																						
Unit No. 6																						
Unit No. 7																						
Unit No. 8																						
Flue-gas desulfurisation plant and new chimney No. 5																						
Wet method Unit No. 10 and chimney No. 5																						
Flue-gas denitrification plants - SCR																						
Unit No. 4																						
Unit No. 5																						
Unit No. 6																						
Unit No. 7																						
Unit No. 8																						
Unit No. 9																						
Unit No. 10																						
Replacement of electrostatic precipitators																						
Unit No. 3																						
Unit No. 4																						
Unit No. 5																						
Unit No. 6																						
Unit No. 7																						
Unit No. 8																						
Unit No. 9																						
Unit No. 10																						

Please note: The projected dates for the decommissioning of Units 1–3 and the installation of selective catalytic reduction (SCR) systems and electrostatic precipitators are provisional. They may change depending on the final requirements of the Industrial Emissions Directive and due to the fact that the SCR installation project is currently in the design specification preparation phase.

The shutdowns of units 1-10 and 11 are planned according to the following schedule⁸

Table 8 Schedule for decommissioning units

Kozenice Power Plant											
Unit	B1	B2	B3	B4	B5	B6	B7	B8	B9	B10	B11
Installed Capacity [MW]	230	230	230	230	230	230	230	230	560	560	1,112
Planned year of decommissioning	2025	2025	2025	2025	2027	2027	2027	2027	2041	2042	2048

⁸ Other information for the extended consolidated report of ENEA S.A. for the third quarter of 2023

Parameters of generating units at the Kozenice Power Plant⁹ :

Table 9 Parameters of generating units

Kozenice Power Plant Capacity: 4,016 MW										
Power of Energy Units [MW]										
B1	B2	B3	B4	B5	B6	B7	B8	B9	B10	B11
228	228	225	228	228	228	228	228	560	560	1075
Voltage Level of Units [kV]										
220	110	220	220	220	110	220	220	400	400	400

Power from the generating units is transmitted via overhead lines to the Kozenice Power Station¹⁰

3.1.2. Planned generating units

The possibility of connecting new generation sources to the National Power System will depend heavily on the geographical allocation of generation sources and electricity consumers, the transmission capacity of the grid, and the time at which the connection of new generation units is to take place. The considerations covered by this study concern the connection of new generation units based on third-generation nuclear reactors to the power system, with a time horizon of more than a decade. Taking into account the above-mentioned time assumptions for the implementation of nuclear sources, the assessment of the feasibility of this project in the analysed location will be influenced by the currently planned generation sources with which the analysed project will compete when it is built, as well as by the transmission capacity of the grid.

Pursuant to Article 7(8)(1) of the Energy Law, an energy company involved in the transmission or distribution of electricity is required to compile information on entities applying for connection of sources to the power grid with a rated voltage higher than 1 kV, the location of connections, connection capacity, type of installation, dates of issue of connection conditions, conclusion of grid connection agreements and commencement of electricity supply.

The project site under consideration is situated directly adjacent to a major network hub, the Kozenice Substation. The main competitors for grid transmission capacity with the analysed project will be the generation sources and energy storage facilities (including those reserving grid capacity for power dispatch from the facility) currently planned for connection to the Kozenice Substation and neighbouring substations, as well as distribution networks (with generation capacity). According to current data published by Polskie Sieci Elektroenergetyczne S.A. (PSE), i.e. the operator of the 220 kV and 400 kV transmission networks in the area where the analysed project is planned, the following generation and storage facilities are planned for the Kozenice SE area and its nearest substations:

⁹ Nowa Energia No. 2 (67)/2019 article by Grzegorz Kotte, Piotr Oberc, Mariusz Opiński, Enea Wytwarzanie Sp. z o.o. "The most modern, largest, most efficient..."

¹⁰ <https://www.openstreetmap.org/way/173582810#map=16/51.6627/21.4656>

Table 10 Selected facilities planned to be connected to the transmission network, to SE Kozenice and neighbouring stations

No.	Connection point (SE)	Power [MW]	Type of installation	Date of delivery/determination of conditions Connection
1	Kozenice	2420	gas and steam unit	10 June 2022
2	Rożki	100.05	photovoltaic installation	6 May 2022
3	Siedlce Ujrzanów	85.8	wind farm	3 October 2022
4	Lublin Systemowa	300.15	photovoltaic installation	2 November 2023
5	Kozenice	112	electricity storage facility	4 November 2019
6	Siedlce Ujrzanów	600	electricity storage facility	12 February 2020
7	Stanisławów	132.9	distribution system	5 July 2021
8	Stanisławów	202.44	distribution system	5 December 2022
9	Siedlce Ujrzanów	202.44	distribution system	9 June 2023
10	Stanisławów	50.6	electricity storage facility	29 June 2023
11	Ostrowiec	50.6	electricity storage facility	4 July 2023
12	Rożki	200	electricity storage facility	18 August 2023
13	Cornets	100	distribution system	22 August 2023
14	Siedlce Ujrzanów	99.53	electricity storage facility	6 October 2023
15	Lublin Systemowa	99.53	electricity storage facility	11 October 2023

In total, facilities with a combined capacity of ~4.7 GW are planned to be connected to the Kozenice Power Plant and stations in its immediate vicinity, including ~2.5 GW to the Kozenice Power Plant alone. The planned gas and steam unit with a connection point at SE Kozenice is being implemented by ENEA Elkogaz Sp. z o.o., owned by ENEA S.A., i.e. the owner (through Enea Wytwarzanie SP. z o.o.) of the Kozenice Power Plant.

3.2. BAT conclusions and related planned coal-fired power plant closures

In recent years, coal-based energy production in the EU has been declining dramatically, with most Member States planning to phase out coal-based energy by 2030. Coal as an energy source will not be economically viable in Poland, e.g. due to rising CO₂ emission allowance prices and energy production costs.

In accordance with the applicable integrated permits¹¹, both fuel combustion installations (i.e. boilers No. 1 to 10 and boiler No. 11) from 18 July 2021 should meet the requirements of the BAT (Best Available Techniques) Conclusions for large combustion plants (i.e. Commission Implementing Decision (EU) 2021/2326).

The above-mentioned permits do not mention any derogations for installations or the inclusion of certain units due to non-compliance with the BAT conclusions. In addition, both permits were issued for an indefinite period. Nevertheless, due to the need to update BAT reference documents every eight years, it can be expected that the requirements for energy combustion installations will be reviewed and may be tightened, particularly with regard to coal fuel. Thus, the units operated in Kozenice may simply not meet the requirements of the new/stricter BAT Conclusions. The adaptation of the above-mentioned units – taking into account in particular consideration of the degree of wear and tear of the above-mentioned units – it will simply be unprofitable.

At the Kozenice Power Plant, eight 200MW coal-fired units are expected to be shut down in the near future. Enea plans to decommission units 1–4 by 2025. The next four units, 5–8, are scheduled to be decommissioned in 2027. The decommissioning of two 500 MW units is planned for 2041 and 2042, respectively¹².

3.3. Characteristics of an open cooling system in the context of its use in a nuclear power plant

The 500 and 200 MW units at the Kozenice Power Plant have an open cooling system, additionally supported by fan cooling towers. For most of the year, the cooling system of the units operates as an open system. During unfavourable periods defined by high cooling water temperatures and low water levels in the Vistula River, fan coolers are activated to cool the heated water flowing out of the condensers of the 200 MW units.

Cooling water is sucked in by pumps to the 200 and 500 block pumping stations. There are eight pumping systems in the 200MW class block pumping station. The suction side of each pump unit consists of water pre-treatment devices such as a grille, flat gate valve and rotary screen. As the minimum cooling water temperature cannot be lower than 6°C in winter, it is heated. In winter conditions, the water intake to the 200MW unit pumping station is protected against freezing by a system that redirects heated discharge water to the cooling water intake (discharge regulating the temperature of the sucked water) and directly to the Vistula riverbed in the area of the inlet to the supply channel (defrosting discharge).

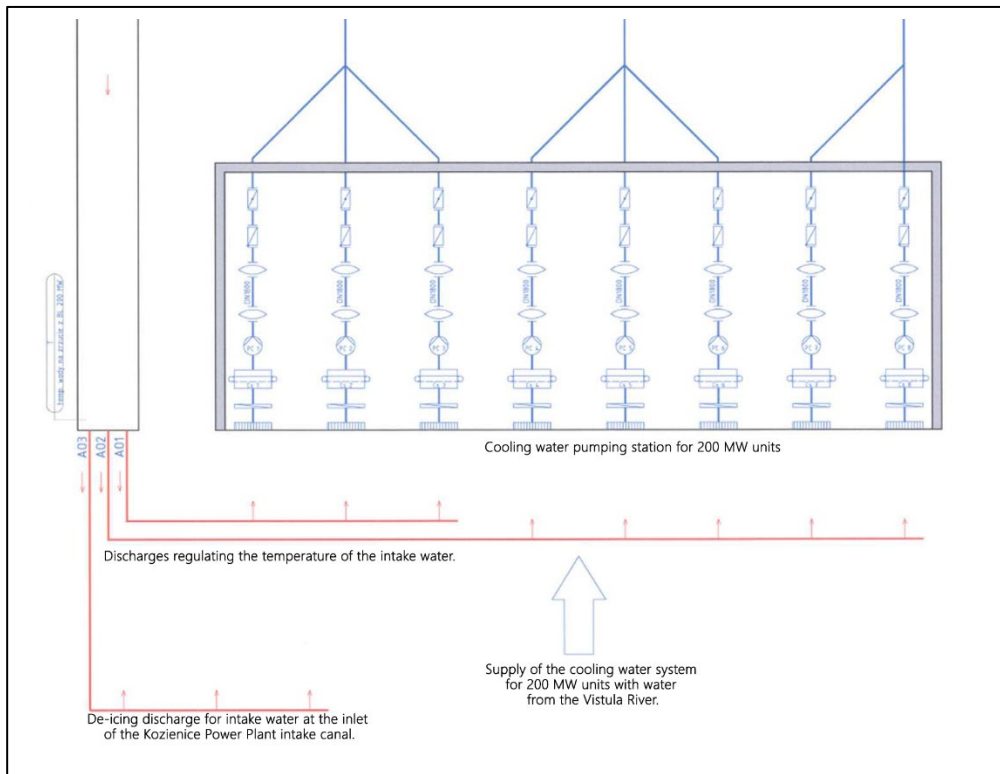

Figure 14 Section of the cooling water system diagram for 8 x 200 MW units

Water from the unit condensers is discharged through DN 2000 pipelines to a siphon well.

¹² <https://www.money.pl/gospodarka/kiedy-koniec-z-weglem-w-polsce-podano-daty-6966508538932096a.html>

The ends of these pipelines must always be submerged in water, which enables the smooth operation of cooling water pumps and protects against air entrapment and siphon breakage. At the water outlet from each reinforced concrete channel to the open channel, there are two pairs of ZR control valves and repair valves (installed as needed). The control valves are designed to maintain the appropriate water level in the siphon wells and, in winter, to direct the heated water to the intake in front of the pumping station. The discharge channels are connected to each other.

During winter, discharge water flows through a reinforced concrete channel to a chamber in front of the pumping station, from where it is directed through three DN 2000 pipelines to the intake for heating. AO – 1 - 3 insulation valves are installed at the inlet to the pipelines. The difference in water levels between the AO chamber and the Vistula River is displayed at the pumping station control room and is to be maintained at a level lower than 170 cm.

The 200 MW unit intake is also used as a water intake for the 500 MW units. Depending on the needs and possibilities, cooling water for the 500 MW units can be taken from the cold water intake, the 200 MW unit cooling water discharge channel, or both sources simultaneously. Cold water is drawn from the intake of the 200MW units via two underwater pipelines with a nominal diameter of DN3000, as shown in the following section of the site plan:

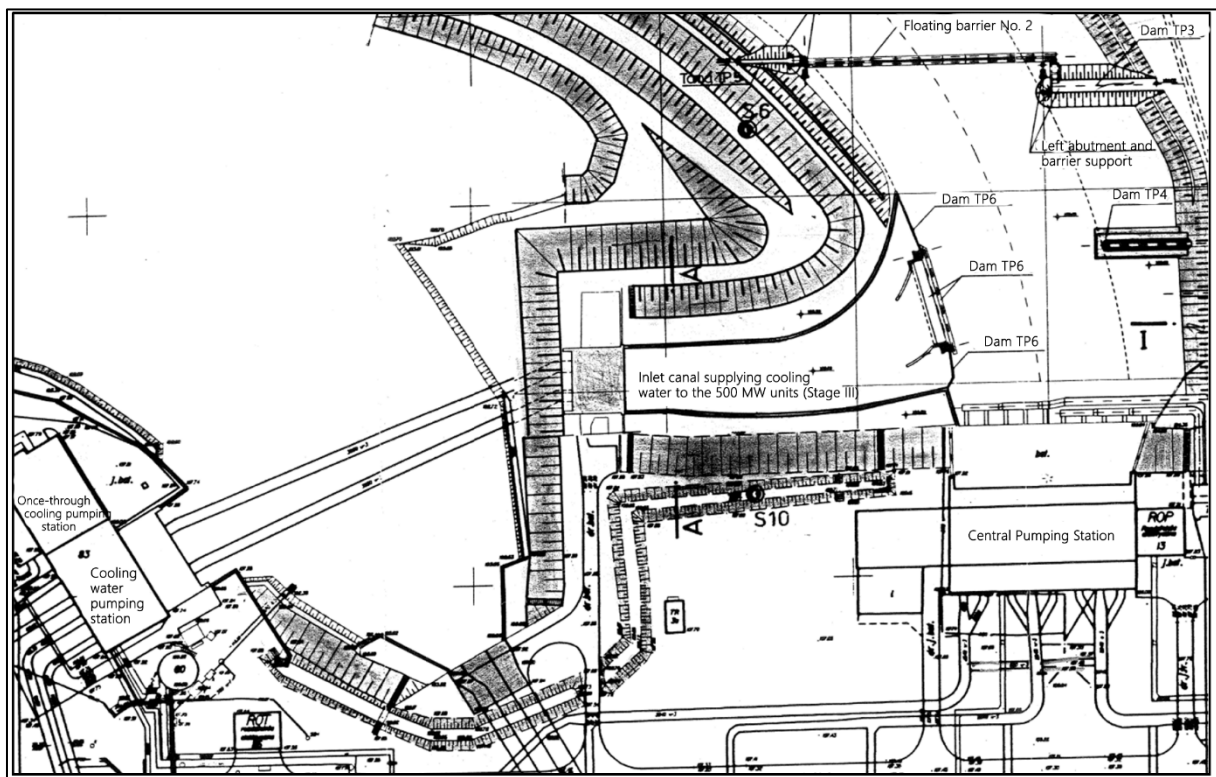

Figure 15 Site plan of the cooling system for units 9 and 10

The cooling water system consists of:

- an open cold water intake channel from the Vistula River,
- proper intake with repair gates, grates and WC 29 - 30 control gates,
- two DN 3000 underwater pipelines supplying cold water to the pumping station,
- hot water intake (discharge from 8 x 200MW blocks) with repair and control valves WC 21 - 28,

- rotary screens 9SO-1, 9SO-2, 10SO-1, 10SO-2,
- cooling water pumps 9NA-1, 9NA-2, 10NA-1, 10NA-2,
- pressure pipelines to turbine condensers,
- check valves 9NA1-KZ, 9NA2-KZ, 10NA1-KZ, 10NA2-KZ,
- self-cleaning filters,
- cooling water discharge pipelines from turbine condensers to reinforced concrete channels,
- impact chamber with WC 31 - 32 control valves,
- self-cleaning grate,
- auxiliary installations

The discharge pipes from both condensers, after leaving the main building, are routed to a two-part underground concrete channel measuring 2 x 2400 x 2400 mm. These channels carry the discharge water to a hydraulic shock chamber, from where it is discharged into the Vistula River via a two-part underground channel measuring 3500 x 3500 mm, or, in the case of high discharge water temperatures, to a flow cooling pumping station. Water discharge from the turbopump condenser is carried out via two DN 508 pipelines, which connect to a single pipeline with a nominal diameter of DN700.

The Koziencice Power Plant has an integrated permit for the permanent abstraction of water from the Vistula River for cooling, replenishing the pore water circulation and desulphurisation installations, with a maximum volume of 100.1 m³/s. The discharged cooling water and treated wastewater generated in the IOS installation must not exceed the maximum permissible temperature of 35°C (temperature resulting from environmental restrictions), which in unfavourable climatic/hydrothermal conditions necessitates a reduction in generation capacity.

Balance calculations for PWR nuclear power plant units from various manufacturers show that the optimal range of steam outlet velocity from the turbine to the condenser is between 150 and 300 m/s. The steam outlet velocity from the turbine depends on the pressure in the condenser, i.e. the vacuum, which is directly related to the cooling water temperature. In order to ensure the required steam outlet velocity from the turbine, the cooling water temperature responsible for the vacuum level should not exceed 24°C (based on calculations by the Silesian University of Technology).

During the summer months, at certain times of the day, the water temperature in the Vistula River significantly exceeds 25°C. Such high cooling water temperatures would adversely affect the operation of the nuclear power plant's turbine set, significantly reducing its power and efficiency, which would result in continuous regulation and reduction of the reactor's power. In addition, the heated water in the condensers could exceed the temperature limit allowed for water to be discharged back into the Vistula River, resulting in a forced reduction in power or shutdown of the reactor.

The cooling circuit of the unit is designed to dissipate the waste heat generated by the power unit into the atmosphere. Two types of cooling circuits are possible at this location: an open or closed system. Heat from the system will be released into the atmosphere via a cooling tower (closed system) or via flow-through condenser cooling (open system).

Below is a comparison of the advantages and disadvantages of constructing a cooling tower or using an open cooling circuit:

Table 11 Comparison of the advantages and disadvantages of open-circuit cooling towers

Cooling tower	Open cooling system
High investment costs	Low investment costs – existing system can be used after modifications
Noise emissions into the environment	No noise emissions
New facility	Use of existing infrastructure
Need to supplement the system	No need to supplement the system – flow cooling
Large building area	-
Possible operational problems during shutdown and when operating at minimum load in winter conditions	Fewer operational problems in winter conditions – great possibilities for insulating channels
Independence from the hydrothermal conditions of the river of the Vistula	Significant operational problems in summer conditions due to due to possible lowering of the water level
The power plant's output is not dependent on external conditions (hydrothermal conditions of the Vistula River)	Possibility of exceeding the cooling water temperature limit, leading to a reduction in power
Negligible impact on the aquatic environment of the Vistula	Destructive impact on the aquatic environment of the Vistula
No heating of the river water	Significant heating of the river water
Negligible suction of living organisms – water intake solely for replenishment of the system	Significant suction of living organisms into the system (larvae, fry, etc.)

The choice of a closed cooling system for each nuclear power plant unit requires the construction of a dedicated cooling tower. This is the preferred solution used by suppliers for facilities built in locations far from the sea.

3.4. "The Vistula threshold" – aspects of use and further operation in the context of nuclear power plant construction

The weir on the Vistula River, used to dam up river water and supply it to the Koźienice Power Plant, was built by ENEA Wytwarzanie in 2017 on the basis of an environmental decision and a construction permit issued in 2016.



Figure 16 Weir on the Vistula River¹³

The function of the weir is to ensure the supply of water necessary for the safe operation of the power plant, specifically for cooling the condensers of the 200 and 500 MW turbine units.

Due to the temporary nature of the hydrotechnical structure that is the dam, its permanent operation cannot be assumed – the Koźienice Power Plant is obliged to demolish the dam.

On 15 February 2021, the Provincial Building Control Inspectorate issued a certificate stating that there were no grounds for objecting to the commencement of the investment project, i.e., the construction of a temporary dam on the Vistula River.

On 23 March 2022, the Governor of Mazovia amended the decision issued on 18 July 2016, namely "the date for the temporary demolition of the dam on the Vistula River was set, i.e. 9 months from the date on which this amending decision becomes final, subject to hydrological conditions favourable for demolition."

The decision on environmental conditions was overturned by the Supreme Administrative Court in its ruling of 7 May 2023.

On 4 December 2023 Enea Wytwarzanie sp. z o.o. sent a letter to the Mayor of Koźienice Municipality requesting that the decision on environmental conditions for the project involving the construction of a temporary dam on the Vistula River be made immediately enforceable. The environmental decision is currently pending.

Despite the completion of construction, Enea does not have a valid environmental decision and has been operating for a long time without the required permit to use the "temporary weir"¹⁴.

3.5. Characteristics of the existing district heating network

Usable heat in the water is generated in four heating units. Heating units No. 1 and 2 operate on a shared network, which supplies facilities located within the power plant, as well as nearby plants and the residential area in Świerże Górne.

Heating unit No. 3 supplies heat exclusively to the greenhouses belonging to Polskie Pomidory S.A. In addition, the power plant also has a heating unit for block 11, which supplies heat for heating, ventilation and domestic hot water production in facilities associated with block 11.

The capacity of heating units No. 1, 2 and 3 is 35 MW_t each, while the capacity of the heating unit of block 11 is approximately 20 MW_t.

The Koźienice Power Plant heating network operates at a supply temperature of 130 °C and a return temperature of 70 °C.

3.6. Characteristics of the emergency power supply system

The emergency power supply system is based mainly on guaranteed voltage switchgears powered by storage batteries. The power plant is equipped with three power generators. Two units are installed on block No. 11. After a power failure on the switchgear, through automation

¹³ <https://elektrowniakozienice.com/upload/default/770x505x4/dji-0012-2-s.jpg>

¹⁴ <https://elektrowniakozienice.com/aktualnosci/13-prog-na-wisle-pozwolenie-na-budowe-zaskarzone-30-09-2019/lang:pl>

Following a power failure at the switchboard, the generators are designed to automatically take over the load of the X1BMA, X1BMB, X2BMA and X2BMB guaranteed voltage switchboards via the automatic transfer switch (ATS) system. One unit is installed at fuel oil pumping station No. 2. Following a power failure at the switchboard, the ATS is designed to take over the load of the RWM and RWN switchboards, which are responsible for supplying power to fuel oil pumping station No. 2 and the fuel oil circulation pumps.

3.7. Construction and road works

3.7.1. Description of the existing development plan

Within the Kozenice Power Plant, as part of the existing units 1-11, there are a number of buildings, structures, roads and squares that serve directly or indirectly for production purposes (electricity generation).

Due to the nature of the proposed construction of new power units based on Generation III/III+ nuclear reactors, it is not possible to use most of the buildings and technological structures located on the premises of the Kozenice Power Plant. In order to make way for the location of the new units, it will be necessary to demolish most of the buildings and utility networks. Section 5.4 of this study presents the proposed area for the construction of new nuclear units. The demolition should cover Units 1-10 together with the accompanying infrastructure (boiler rooms, engine rooms, IOS, coal yards and others). After demolition and removal of debris and steel structures, in many cases it will be necessary to replenish the ground to a level consistent with the surrounding area (macro-levelling) or to reclaim the land (in the case of coal yards). Due to the nature of the existing buildings (deep foundations), it should be expected that the depth of the necessary macro-levelling may in many cases be as much as 5 metres or more, which may significantly affect the costs of such a project.

3.7.2. Description of the existing road system

There are five entrance gates leading to the Kozenice Power Plant. Their schematic location is shown in the figure below:

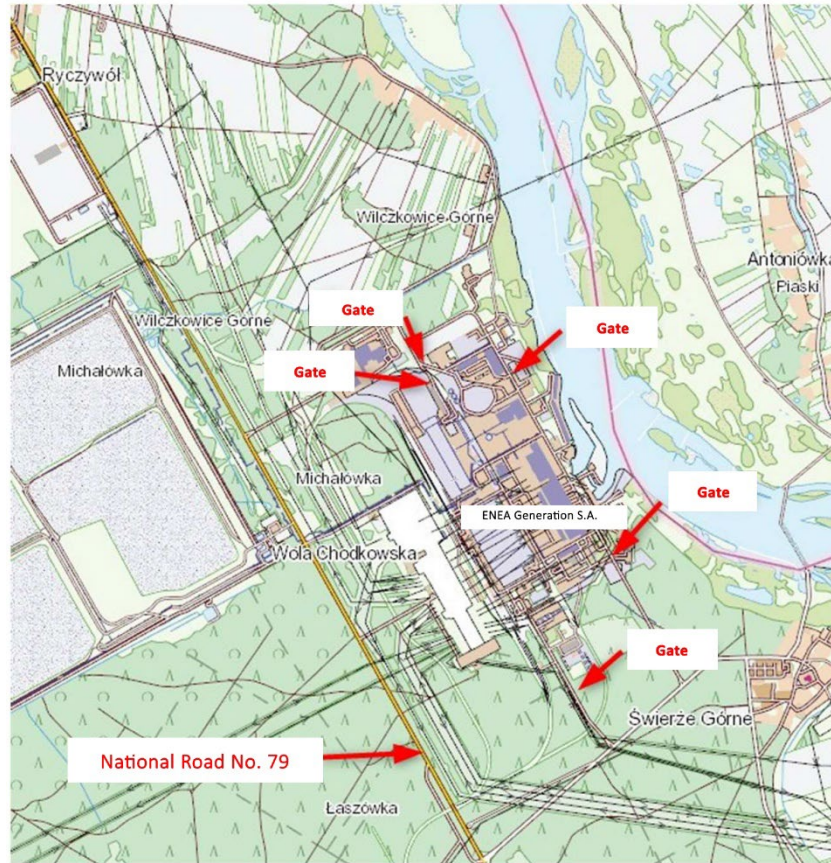

Figure 17 Layout of entrances to the Kozenice Power Plant¹⁵

The power plant has an internal road system with pavements, car parks and storage areas.¹⁶

The Kozenice Power Plant is surrounded by a network of public roads, including national and provincial roads:

- National road No. 79
- National road No. 48
- Provincial road No. 736
- Provincial road No. 737

and the network of district roads shown in the figure below.

¹⁵ <https://www.geoportal.gov.pl/>

¹⁶ <https://www.geoportal.gov.pl/>

1746W Świerże Górne - ferry - voivodeship border - Antoniówka

- **Route:** From county road 1718W – Świerże Górne – ferry /Vistula River/ – Lublin Voivodeship border.

3.7.3. Description of the existing railway system

Public railway lines

Railway line No. 77: Janików – Świerże Górne – a secondary, single-track, electrified railway line of national importance, connecting the Janików passing loop and the Świerże Górne station. The construction of the railway siding began in 1968 to serve the Kozienice Power Plant. The line is still used for this purpose today (2020).

The entire line is class D3, with a maximum axle load of 221 kN for locomotives and carriages, and a maximum line load of 71 kN (per metre of track). The line is equipped with a YC120-2C traction network, adapted to a maximum speed of 120 km/h, a current load capacity of 1725 A, and the minimum distance between current collectors is 20 m. The line is equipped with electromagnets for automatic train braking. The line is subject to the construction area of the Lublin Railway Line Management Centre, as well as the Skarżysko-Kamienna Railway Line Plant. The maximum speed of trains on the line is 50 km/h, and its design speed is 80 km/h.¹⁸

Railway line No. 77 then connects with line No. 76: Bąkowiec – Kozienice – a secondary, single-track, electrified railway line of national importance, connecting the Bąkowiec station and the Janików passing loop¹⁹. It then connects with railway line No. 577 and the primary railway line No. 26 Łuków – Radom Główny. It is an electrified, single and double-track line. The speed limit on the line is 120 km/h²⁰

¹⁸ https://pl.wikipedia.org/wiki/Linia_kolejowa_nr_77

¹⁹ https://pl.wikipedia.org/wiki/Linia_kolejowa_nr_76

²⁰ https://pl.wikipedia.org/wiki/Linia_kolejowa_nr_26

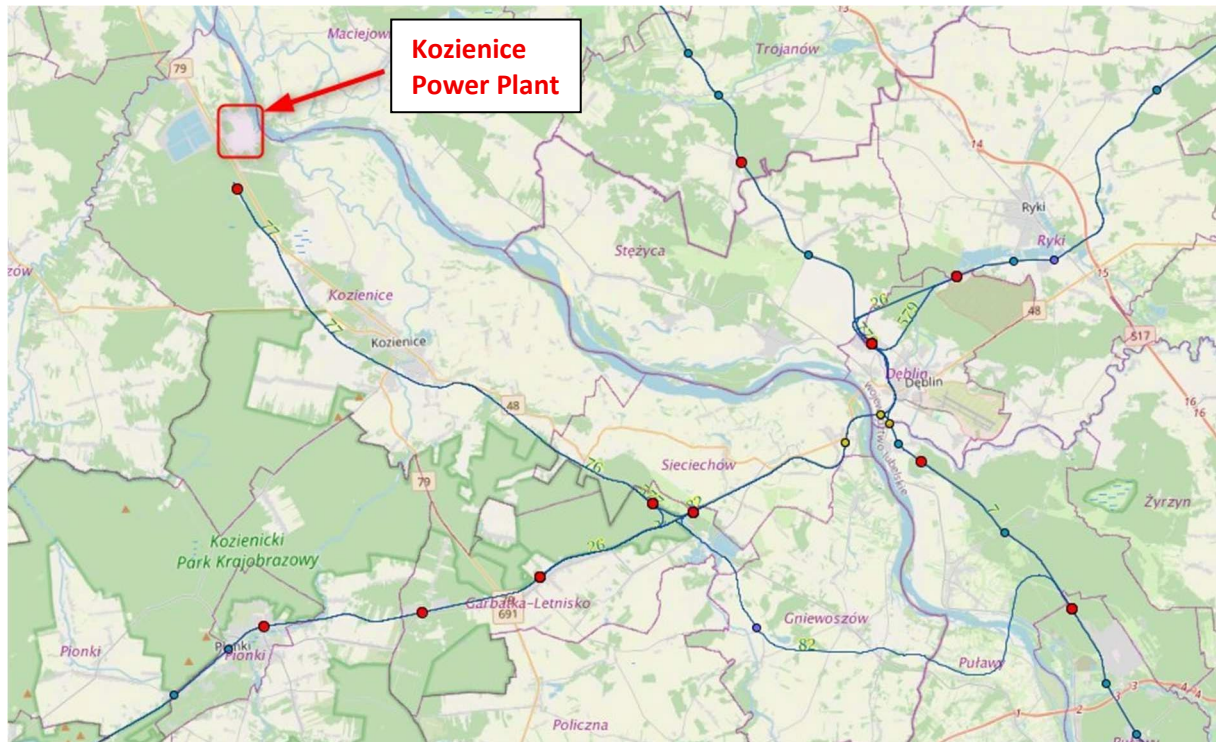

Figure 19 Diagram of state railway lines in the Kozienice Power Plant area²¹

Internal railway lines

The power plant has a railway track system connected to the Polish Railway Lines system via the Świerże Górne railway station with the 77 Janików-Świerże Górne railway line. The layout of the tracks and their connection to line no. 77 is shown in the figure below.

²¹ <http://mapa.plk-sa.pl/>

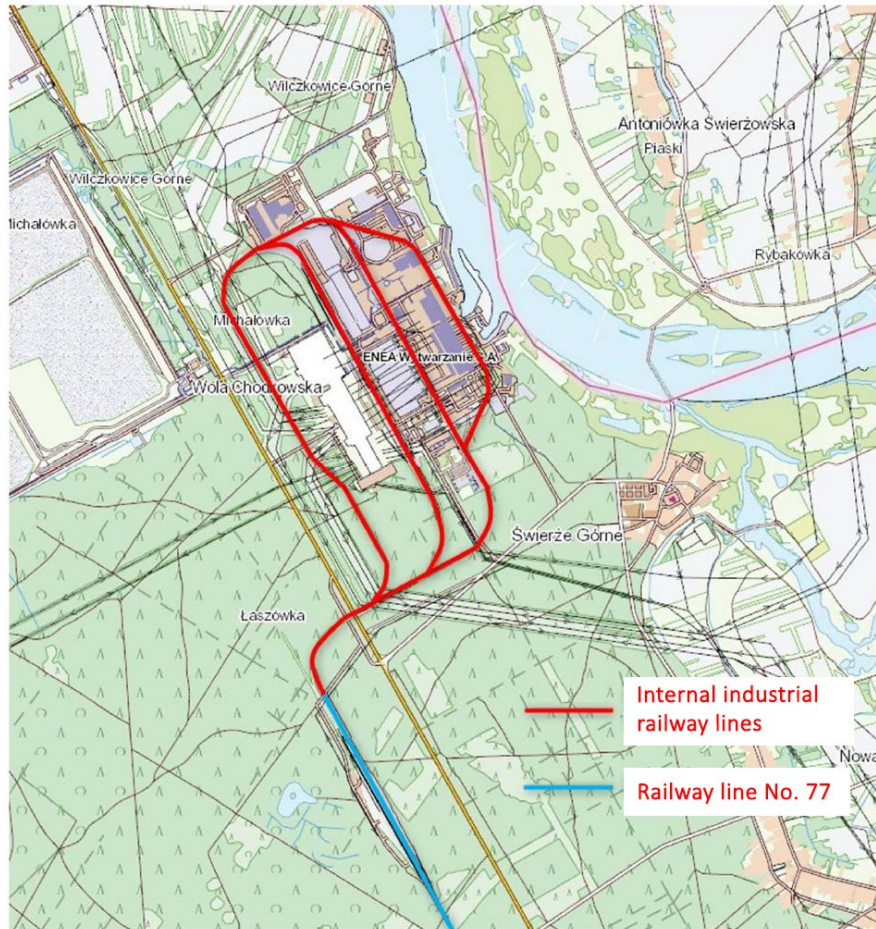

Figure 20 Diagram of railway lines on the premises of the Kozienice Power Plant²²

3.7.4. Description of geological and water conditions

Geological conditions

The geological conditions were characterised on the basis of publicly available sources.²³

The analysed area of the Kozienice Power Plant is located in the Middle Vistula Valley, which is part of the central part of the Central Mazovia Lowland macroregion.

This region has an elongated meridional shape with a width of approx. 10 km, covering the Vistula valley between Puławy and Warsaw. Two geological sub-areas can be distinguished in this area: floodplain meadows (lower) and sandy dunes (higher). The Middle Vistula Valley region mainly features natural landscapes of floodplain valleys – accumulation valleys. Within its boundaries lies the Vistula valley between Warsaw and Puławy, approximately 10 km wide. It is filled with Holocene geological formations forming a floodplain terrace – sands, gravels, river alluvial deposits, peats and silts. Slightly smaller areas (mostly covered with forest) are occupied by Pleistocene sands, gravels and river silts from the North Polish glaciation, which, together with a few islands of aeolian sands locally in the dunes, form floodplain terraces.

²² <https://www.geoportal.gov.pl/>

²³ <https://geologia.pqi.gov.pl>

Based on the available soil test cards, it can be concluded that the area in question contains moderately compacted fine and medium sand. The groundwater level is ~102 m above sea level (~-5.30 m).

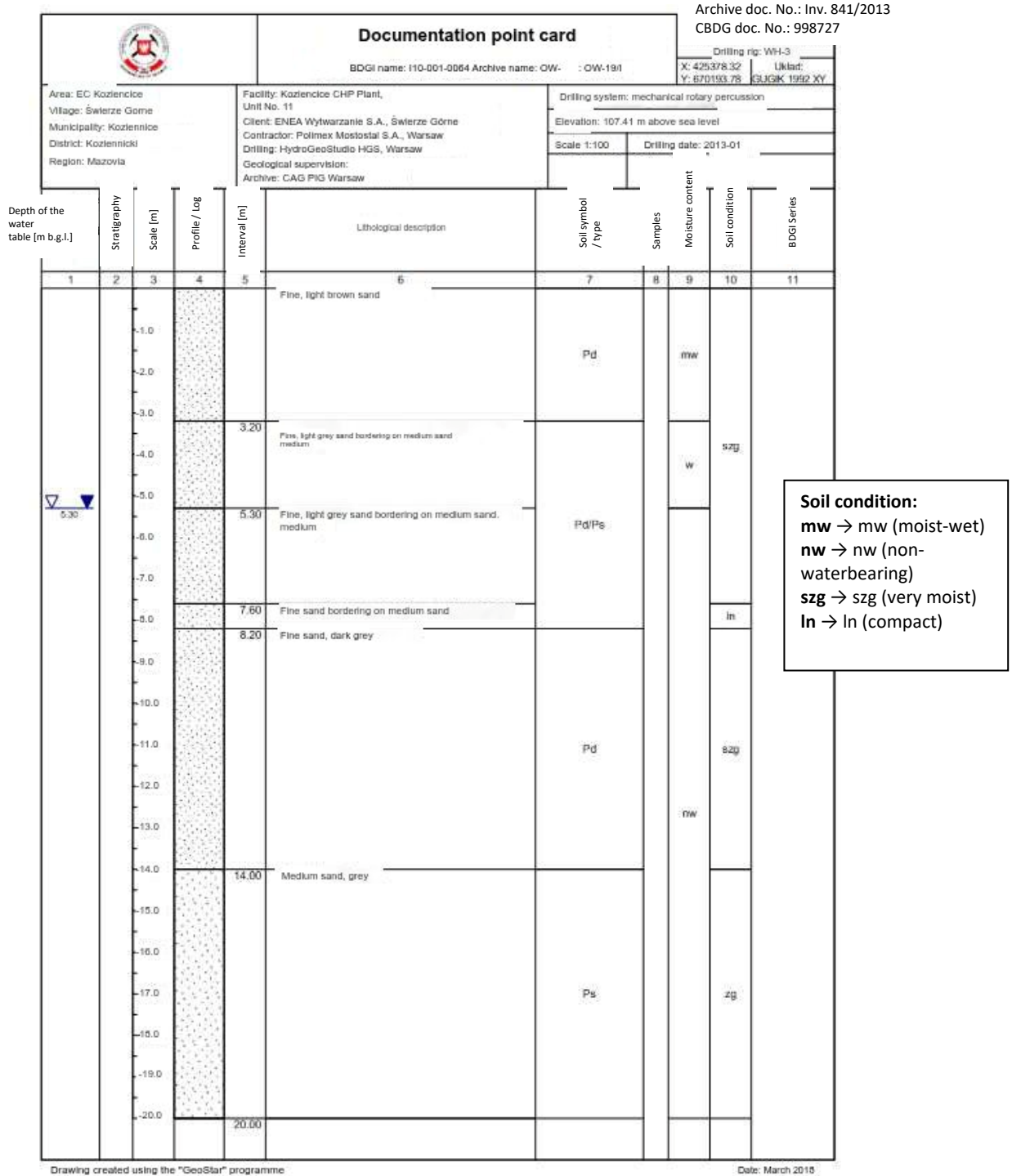

Figure 21 Sample soil test report²⁴

²⁴ <https://geologia.pgi.gov.pl>

3.7.4.1. Identification of flood risk

The area in question at the Kozenice Power Plant is located in a flood risk area (Q1%, i.e. once every 100 years)²⁵. The map below shows that a significant part of the analysed area is at risk of flooding.

Areas at risk of flooding

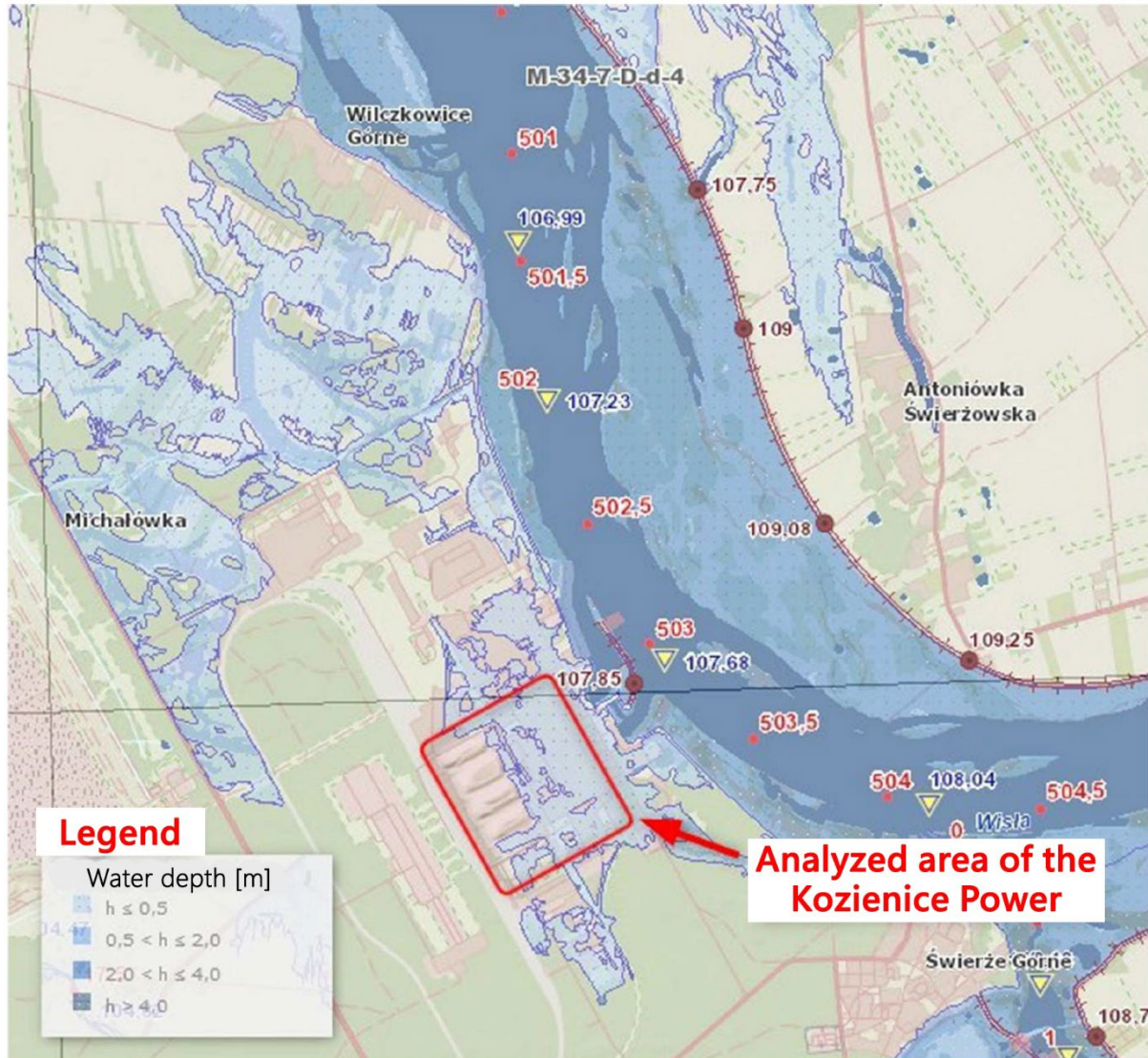

Figure 22 Flood risk area²⁶

The current Local Spatial Development Plan for parts of the following cadastral districts: Wilczkowice Górne, Michałowka, Świerże Górne in the municipality of Kozenice uses flood risk maps, but these maps do not take into account the technical flood barriers located on the premises of Enea Wytwarzanie in Świerże Górne.

A technical assessment on flood protection measures in the area and on the site of Enea Wytwarzanie in Świerże Górne is currently being updated with a view to identify flood risk areas in terms of the implementation of:

²⁵ <https://wody.isok.gov.pl/>

²⁶ <https://wody.isok.gov.pl/>

- A digital terrain model (DTM) created using "lidar" laser-scanning technology with an orthophoto map of flood protection measures for the site of Enea Wytwarzanie sp. z o.o. (Kozienice),
- hydraulic analysis for flow with a 1% probability of occurrence (Q1%) based on the existing hydraulic model made available by PGW Wody Polskie using the new DTM described above,
- hydraulic analysis for flow with a Q0.2% hazard probability based on the existing hydraulic model made available by PGW Wody Polskie using the new DTM described above

In the future, it is planned to update the flood risk and hazard maps in terms of the classification of floodplains in the area of the Kozienice Power Plant.

3.8. The electrical system for auxiliary power

The plant's own needs are supplied from a 110 kV overhead line and, via 110/6 kV transformers, supplies the individual 6 kV switchyards of the units.²⁷ The transformers of units 1-10 have been modernised, but they will not be used for the new nuclear unit due to their age and the different voltage level of modern MV switchgears (previously 6kV, currently 10.5-15kV).

The internal needs of unit 11 are supplied by two transformers: XOBBT10, S=120/60/60 MVA and XOBBT20, S=100/50/50 MVA with a ratio of 27/10.5 kV. At the time of commissioning the nuclear unit, these units will already be worn out (in 2040 they will be 23 years old) and, as in the case of units 1-10, there will be a problem with matching the voltage levels to the new generating unit. There is a possibility of using them.

3.9. Power output



Blocks 1-10 have power output from generators via three-phase block transformers located along the wall of the engine room on the Vistula side. The power is then transmitted via overhead lines suspended on poles attached to the boiler room roof and further via poles across the coal handling yard to the Kozienice Power Station.



Unit 11 has power output from the generator via a system of three single-phase transformers installed next to the machine building and then via overhead lines on poles to the Kozienice Power Station.²⁸

²⁷ New Energy, Grzegorz Kotte, Piotr Oberc, Mariusz Opiński, Enea Wytwarzanie Sp. z o.o. "The most modern, the largest, the most efficient..." („Najnowocześniejszy, największy, najsprawniejszy...")

²⁸ <https://biznesalert.pl/nowy-blok-w-elektrowni-kozienice-roz poczyna-prze glad-gwarancyjny/>

3.9.1. General characteristics

Below are the general characteristics of units B1-B11 with their assigned capacities and power output system voltage levels²⁹:

Table 12 General characteristics of units B1-B11

Kozienice Power Plant Capacity: 4016 MW										
Capacity of Power Units [MW]										
B1	B2	B3	B4	B5	B6	B7	B8	B9	B10	B11
228	228	225	228	228	228	228	228	560	560	1075
Voltage Level of Units [kV]										
220	110	220	220	220	110	220	220	400	400	400

3.9.2. Block transformers

The block transformers for blocks 1-10 are three-phase. Due to their age, power rating and voltage levels, it will not be possible to use them in the new nuclear system.

The block 11 block transformer is a single-phase system with a capacity of 3x450MVA. It is possible to adapt these units to operate in the new nuclear system.

3.9.3. Block transformer frontcourts



Blocks 1-10 have bays with block transformers located on the Vistula River side³⁰. The bays are relatively small and narrow due to underground channels that draw water from the Vistula River for cooling purposes. The construction of the channels prevents the expansion of the bays. Power from the units is transmitted via overhead lines to the boiler roof and further to the Kozienice Power Station (owned by PSE).³¹

²⁹ Grzegorz Kotte, Piotr Oberc, Mariusz Opiński, Enea Wytwarzanie Sp. z o.o. "The most modern, largest, most efficient..." Nowa Energia No. 2 (67) / 2019

³⁰ <https://www.google.pl/maps/place/26-900Kozienice/@51.6662516,21.4650226,496m/data=!3m1!1e3!4m6!3m5!1s0x4718922352c884fb:0xbe5b6eeb9f563c43!8m2!3d51.5855328!4d21.5511768!16zL20vMDIyOHMz?entry=ttu>

³¹ <https://swiatoze.pl/najnowszy-blok-energetyczny-elektrowni-kozienice-osiagnal-moc-nominalna/>



Block No. 11 has a forecourt located on the left side of the engine room, where a 400kV overhead line pole has been built.

Power is supplied via three 1-phase 27/400kV transformers, $S=450\text{MVA}$.³²

Depending on the planned decarbonisation, the size of the built-in nuclear boiler and the output voltage level from the generator, it will be possible to use front-end equipment³³.

3.9.4. Power transmission lines

Power transmission lines are a component of the power system designed to transmit power from specific generating units. Due to their purpose, their technical specifications do not require oversizing to accommodate future investment plans.

The existing power lines from the Kozenice Power Plant are used to transmit power from the remaining operational units 1-11, at voltages of 110 kV, 220 kV and 400 kV, to the Kozenice Power Station substation. Due to the technological layout of the Kozenice Power Plant, the power lines from the units are located on the opposite side to the Kozenice Power Station (a solution used in power plants built during that period). This makes it necessary for the lines to bypass/cross the power plant buildings.

- The 110 kV block lines for blocks 2 and 6 are overhead lines running from the south of the power plant, encircling the power plant buildings and coal yards.
- The 220 kV block lines of blocks 1, 3-5, 7 and 8 are overhead lines running above the power plant buildings and coal yards. The line gates are located on the roof of the existing boiler house buildings.
- The 400 kV block lines for blocks 9 and 10 are overhead lines running above the power plant buildings and coal yards. The line gates are located on the roof of the existing boiler house buildings.
- The 400 kV line of unit No. 11 is overhead and runs between the buildings of units 11 and 10.

Due to the time when they were built, the power lines of units 1-10 do not meet the current regulatory requirements for the design of overhead lines.

3.9.5. Kozenice power station

The SE Kozenice substation is located near the Kozenice Power Station in Świerże Górne and is used to transmit power from the power station, as well as to transit and distribute electricity at voltages of 400, 220 and 110 kV. The substation is owned by PSE S.A.

³² <https://www.urzadeniadlaenergetyki.pl/laczniki-w-eksploatacji-2018/doswiadczenie-abb-sp-o-o-zakresie-dostawy-uruchomienia-urazden-dla-wyprowadzenia-energii-bloku-elektrowni-o-mocy-1075-mw/>

³³ <https://www.polimex-mostostal.pl/page/kozenice>

The station (as of 2032) will be connected to the National Power System via eight 400 kV lines, including three to the south (Połaniec, Stalowa Wola), one to the east (Chełm) and four to the north (Warsaw, Miłosna, Siedlce), and six 220 kV lines, including two northbound (Warsaw, Piaseczno), two south-westbound (Radom, Kielce) and two south-eastbound (Puławy, Lublin). The strong connection of the substation to the power system, on the one hand, ensures good potential for the transmission of significant volumes of power through the node, while on the other hand, the station's ability to introduce additional generation capacity into the system is limited by "macro" north-south flows—resulting from the planned significant generation in the north of the country (related to the decommissioning of conventional sources in the south) and flows from the east caused by energy overproduction along the eastern border with low regional demand for power/energy.

The Koźienice power station is an important hub in the National Power System, particularly in terms of energy security for the Warsaw agglomeration and the north-eastern part of the country. The station consists of three switchyards: 110 kV, 220 kV and 400 kV, as well as 110/220 kV and 220/400 kV transformers.

- The 400 kV substation is the newest in SE Koźienice, overhead, 14-bay substation, operating in a one-and-a-half circuit breaker configuration.
- The 220 kV substation is an overhead, 26-bay, dual-system switchyard with a bypass busbar.
- The 110 kV switchgear is an overhead, 22-bay, dual-system switchyard with a bypass busbar.



Figure 23 Koźienice Power Station

The 220 kV and 110 kV switchgears were built during the construction of the 200 MW-class power plant units. Considering the existing structural layout of both the 220 kV and 110 kV switchyards and based on experience with similar facilities, it must be concluded that these switchyards are at risk of insufficient short-circuit withstand capacity, in particular in connection with the planned connection of new generation and storage units with a total capacity of 2.5 GW (see section 3.1.2).

In accordance with the Development Plan for meeting current and future electricity demand for the years 2023-2032, item II.8, upgrades are planned for the Kozenice substation, specifically the 220 kV and 110 kV switchyards. The investment project aims to improve the technical condition and operating conditions of the switchyards (alignment with the technical standards of PSE S.A.). The modernisation is planned to be completed by 2033.

As part of the modernisation of the substation, it will be expanded to connect the planned projects (in accordance with section 3.1.2), combined cycle gas turbines and energy storage facilities.

3.9.6. Other power engineering systems

The Kozenice Power Plant has telecommunications links with the systems of PSE, the operator of the National Power System. These systems can be used in the new unit once the formal requirements between PSE and the new operator of the new nuclear unit have been met.

3.10. Water and wastewater infrastructure (excluding technical equipment)

The water and sewage infrastructure (excluding technical equipment) at the Kozenice Power Plant comprises in particular the following on-site networks:

- drinking water, including a water treatment plant and groundwater intake,
- fire-fighting water;
- rainwater and industrial drainage networks, including rainwater and industrial wastewater treatment plants for units 1-8 and 9-10, as well as unit 11, with two outlets (water discharge points) for the above-mentioned wastewater into the Vistula River;
- domestic sewage system with a domestic sewage treatment plant and an outlet (water facility) of the above-mentioned sewage into the Vistula River.

3.11. Diagnosis of the possibilities of using the existing infrastructure of the site – summary

Based on the assessment of the existing infrastructure, assuming that the construction of a new Generation III/III+ nuclear power plant for the Kozenice location will make maximum use of the existing infrastructure, especially in terms of internal and external water sources, transmission networks, and road and rail infrastructure, a preliminary assessment was made for individual areas.

Currently, the location in question has infrastructure for operational coal-fired power units, which, according to the project's assumptions, can only be utilised to a limited extent in the design and construction of a new nuclear power plant.

Technology industry

An analysis of the technical condition of the existing infrastructure at the Kozenice Power Plant revealed that the only usable system among the existing units 1-10 is a cooling water intake and discharge system, including the intake and preliminary water filtration equipment. The use of other elements of the open cooling system, i.e. pumping stations and pipelines, will mainly depend on the choice of the cooling system type for the new nuclear power plant, which is described later in this study.

Due to its planned operating life until 2050, Unit 11 was not considered in the context of using its infrastructure for the construction of a third-generation nuclear unit. After the end of its operational life, it will be possible to use part of the infrastructure, e.g. the cooling system together with the cooling tower, for the construction of a new nuclear power unit, which could be built on the site of the existing Unit 11.

Additionally, at an earlier stage of the project, Unit 11 was analysed in terms of the use of its infrastructure in the context of the construction of Generation IV nuclear reactors to replace the existing coal-fired boiler. The analysis of the possibility of replacing the Unit 11 boiler with low-power nuclear reactors was not covered by this Pre-Feasibility Study.

Electricity industry

Due to the varying age and quality characteristics of the existing infrastructure, the assessment of its use for the implementation of nuclear projects was divided according to generating units.

Units 1-10 – it is not possible to use the existing electrical infrastructure. The existing power output systems, including overhead lines, pylons, support structures, block and auxiliary transformer stations, and the power supply systems for the units' own needs will be dismantled and demolished.

Unit 11 – there is a potential possibility (depending on the generator power and power demand for internal consumption) of using (for Generation IV reactors):

- generator,
- generator circuit breaker,
- busbar system from the generator to the unit transformer/tap-off transformer

- single-phase unit transformers,
- three-winding, three-phase tap-change transformers,
- overhead power feed-through and backup power supply system,
- telecommunications connections between block no. 11 and PSE.

The potential for utilising the existing electrical infrastructure of Unit 11 depends on the feasibility of adapting the nuclear technology used and its power capacity to the parameters of the existing unit. It should be noted, however, that unit 11 is one of the newer domestic coal-fired power plants and its decommissioning for modernisation using nuclear reactors may not be possible for reasons related to the National Power System load balance.

Installation sector

Considering the planned new layout of facilities associated with nuclear power units, provision must be made for the installation of a new on-site network system comprising: domestic water, fire-fighting water and sewage systems. This is because the existing layout cannot be used in the planned new site development.

Potentially, at later stages of design, when all quantitative and qualitative parameters regarding water demand and sewage disposal are known, the possibility may be considered of using a deep-well water intake with a water treatment plant, or existing wastewater treatment plants and wastewater discharge outlets to the environment. However, given the long-term operation of these facilities to date and their potentially insufficient capacity for the new installation, this is not a recommended solution. Rather, it is necessary to anticipate the need for new water treatment and wastewater treatment installations, with only the potential possibility of using the existing water facilities for water intake and wastewater discharge. Of course, this is only on the assumption that their capacity/throughput and technical condition at the time of planned use will be sufficient.

4. Market analysis of the suppliers of technology required for the investment process

4.1. Assumptions

The plan for decarbonising the national commercial energy sector using Coal-to-Nuclear technology in this study envisages the use of Generation III/III+ nuclear reactors. Reactors of this generation have many advantages, including:

- Simpler and more robust reactor building design
- They mostly use passive cooling systems based on natural phenomena, such as evaporative cooling
- Lower probability of serious accidents involving core meltdown
- In the event of a core meltdown accident, its impact on society and the environment has been significantly reduced.

- The reactor building is designed to be resistant to a direct impact from a large aircraft
- Extended fuel cycle and higher fuel burn-up
- Reduced amount of radioactive waste generated
- Operating life of up to 60 years

4.2. Market of suppliers

Currently, the market offers several specific and proven technologies for this generation of reactors. Three PWR (pressurised water reactor) reactors, i.e. pressurised water reactors, were selected for further analysis:

- **AP 1000** – a reactor manufactured by Westinghouse (USA) with a net electrical output of 1,150 MW
- **APR 1400** – reactor manufactured by KHNP (South Korea) with a net electrical output of 1,450 MW
- **EPR** – a reactor manufactured by EDF (France) based on the experience of German KONVOI and French N4 reactors with a net electrical power of 1,600 MW

AP1000 – Advanced Passive – an advanced, light water passive reactor with two cooling loops and a thermal power of 3,415 MWt. The cooling loops are equipped with main circulation pumps located directly on the outlet nozzles of the steam generators, i.e. on the cold side of the circulation loop. This solution eliminates the need for piping between the steam generators and the pumps.

The reactor core consists of 157 fuel assemblies of seven types using UO_2 as fuel material. Individual fuel assemblies have varying degrees of enrichment and may contain combusting coating in the form of a thin layer of ZrB_2 (zirconium diboride) on the surface of the fuel pellets, and special ring-shaped rods made of $\text{AL}_2\text{O}_3\text{B}_4\text{C}$, which together ensure an even power distribution within the core. The time between fuel replacements has been extended to up to 18 months, with a capacity factor of approximately 93%.

The AP1000 reactor uses fully passive emergency cooling systems, i.e., these systems do not have pumps and do not require emergency power supplies such as diesel generators. The supply of borated water to flood the core in the event of a coolant loss accident is ensured by three water sources:

- two coolant purification and replenishment tanks
- two hydroaccumulators maintained at a pressure of 4.9 MPa by a nitrogen cushion
- a tank inside the safety enclosure used to condense pressure stabiliser vapour and collect post-shutdown heat, and as a water reservoir to flood the reactor in the event of core meltdown.

A nuclear power plant based on the AP1000 reactor has 35% fewer pumps, 80% fewer safety-related pipelines and half as many safety valves as a lower-generation nuclear unit of similar capacity. Most of the safety installations are housed in a two-layer safety enclosure: an inner steel layer and an outer concrete layer. The inner steel enclosure is designed to prevent any leaks from the reactor. The upper part of the safety enclosure houses a water tank with a capacity of approximately 3,000 m³, the purpose of which is to cool the inner steel casing.

Passive cooling systems are designed to ensure conditions for safe reactor shutdown for 72 hours after a failure without the need for operator intervention.

The probability of core meltdown is estimated at less than 2.4×10^{-7} /year.

APR1400 – Advanced Power Reactor – an advanced pressurised water reactor with two cooling lines in each loop. The APR1400 reactor is manufactured by Korean Electric Power Corporation (KEPCO) and Korea Hydro and Nuclear Power (KHNP).

The reactor fuel system consists of 256 cassettes containing 236 fuel rods each. The fuel material is UO_2 , but some cassettes contain an admixture of gadolinium trioxide (Gd_2O_3) as a burn-up additive. The reactor can also use reprocessed MOX fuel, which accounts for 33% of the primary fuel.

The main safety systems include the core emergency flooding system, the overpressure relief system with steam removal, the containment sprinkler system, and the emergency feedwater system. The containment also houses a water pool for fuel reloading; in an emergency, water from the pool is used to flood the core. The flooding system has been simplified, equipped with four redundant lines with direct water injection into the reactor vessel and a dual electrical power supply system. Each emergency cooling line has an active section using a pump and a passive section with a coolant reservoir and flow regulator.

The safety enclosure is approximately 1.37 m thick and is made of compressed concrete covered on the inside with a steel shell to protect against leaks. The enclosure also provides resistance to earthquakes with an acceleration of 0.3G.

The probability of core damage is estimated at less than 10^{-5} per year, and damage to the safety enclosure at less than 10^{-6} per year.

Nuclear power units currently in operation with the APR1400 reactor include Shin-Kori 3, 4, 5 and 6.

EPR – European Pressurised Reactor – a German-French design, it is the largest PWR reactor with a maximum electrical output of approximately 1,650 MWe.

The main fuel for this reactor is UO_2 , but MOX fuel can also be used, with or without gadolinium at a concentration of 2% to 8% as a burn-up additive. An M5 alloy containing zirconium and a 1% niobium additive was used to manufacture fuel cladding, spacer grids and fuel cassette tubes. The use of the M5 alloy has increased resistance to corrosion and creep, as well as dimensional stability.

An innovative feature of the EPR reactor is the use of a heavy reflector, which limits the escape of neutrons hitting the vessel wall. This has improved neutron management, contributing to a reduction in fuel enrichment and an extension of its operating time in the reactor. It is estimated that fuel costs can be up to 17% lower than for other types of operating PWR reactors.

This reactor also features higher thermodynamic efficiency of the system, i.e., approximately 36%. Higher efficiency is achieved through high pressure on the secondary side of the reactor – 7.72MPa.

The safety enclosure for EPR technology consists of two layers of concrete.

They include the reactor, fuel storage pool and two buildings housing the most critical safety systems. The containment structure is designed to withstand the impact of a large passenger aircraft. As with other Generation III/III+ reactors, the EPR has a steel liner inside the concrete containment structure to prevent leaks.

The safety system consists of four separate sections of emergency core flooding systems and feedwater systems, together with auxiliary infrastructure. Another safety system is the borated water pool, used during normal operation for fuel reloading and, in the event of an accident, as a source of water for cooling the core (including a molten core) and the containment.

Table 13 Comparative table of Generation III/III+ nuclear power plants

System/parameter		AP1000	APR1400	EPR
General characteristics				
Reactor type		PWR	PWR	PWR
Net electrical output	MWe	1110	1450	1650
Thermal output	MWt	3415	4000	4590
Net efficiency	%	32.6	35.1	36
Operating lifetime	years	60	60	60
Number of units in operation/under construction	pcs	4	4/6	3/3
Cooling circuit (primary)				
Number of loops	pcs	2	2	2
Number of circulation pumps	pcs	4	4	4
Maximum water pressure	MPa	17.2	17.2	17.6
Operating water pressure	MPa	15.51	15.51	15.5
Temperature at the core inlet	°C	279.4	290.6	295.7
Temperature at the core outlet	°C	324.7	323.9	329.9
Water temperature rise in the core	°C	45.3	33.3	34.2
Feed water temperature	°C	226.7	232.2	230
Coolant flow through the core	tonnes/s	14.3	20.991	22.225
Steam pressure at the generator outlet	MPa	5.79	6.9	7.72
Steam temperature at the turbine inlet	°C	272.8	285	293
Steam flow through the generators	kg/s	1889	1130.8	2604
Fuel assembly characteristics				
Cassette layout/grid		17x17	16x16	17x17
Number of fuel rods	pcs	264	236	265
Number of guide tubes	pcs	25	20	24
Number of cassettes in the core	pcs	157	241	241
Number of control rods in the core	pcs	53 (black) 16 (grey)	93	89 (black)
Length of the fuel part of the cartridge (cold state)	cm	426.7	381	420
Average power density in the core	MW/m ³	109.7	100.9	94.6
Fuel rods				
Number of rods in the core	pcs	41,448	56,876	63,865
Average power density per unit length	W/cm	187	183.8	163.4
Fuel cladding material		ZIRLO	Zircaloy-4	M5
Fuel pellets				
Fuel material		UO ₂	UO ₂	UO ₂ or MOX
Maximum enrichment	%	≤5	3.64	≤5
Fuel operating lifetime in the reactor	m-ce	18	≥18	18.24

Reactor vessel				
Internal diameter at core level	m	4.039	4.655	4.870
Vessel wall thickness	cm	20.3	28.4	25
Equivalent core diameter	cm	304	363	376.7

Thermodynamic calculations for the analysed nuclear reactors were performed using the STEAM PRO programme included in the Thermoflow package. The thermodynamic models take into account a number of technical parameters presented, among others, in the table above and in the report from task No. 3 performed by the Silesian University of Technology in Gliwice. In addition, data presented by the International Atomic Energy Agency (IAEA) was also used.

The model primarily covers the steam section of the nuclear block, without a detailed analysis of the reactor, whose parameters were adopted in accordance with the guidelines. Furthermore, at this stage, no cooling system has been determined; for comparison purposes, all models were made for an open system at the same ambient temperature of 15°C. The final results of the model may differ from the data presented in the table due to different cooling system parameters.

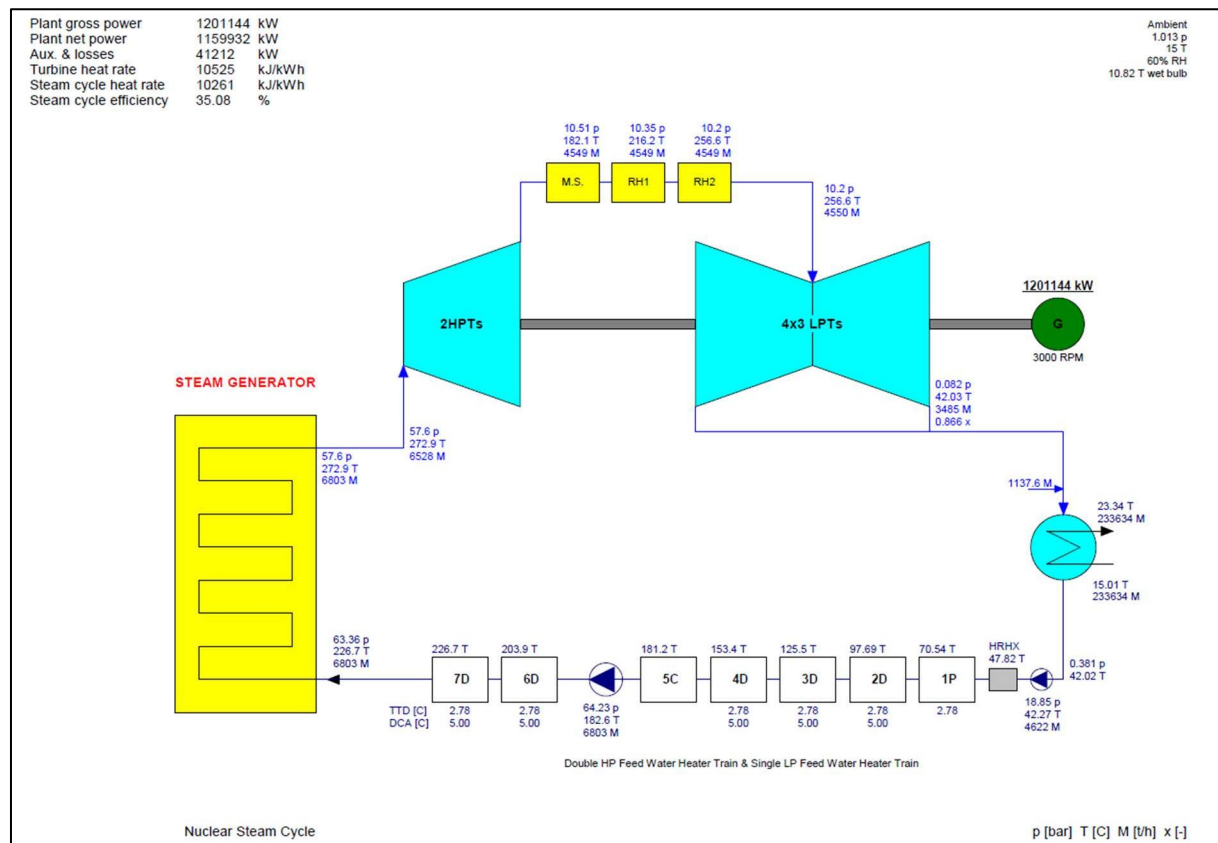

Figure 24 Steam diagram of the AP-1000 unit

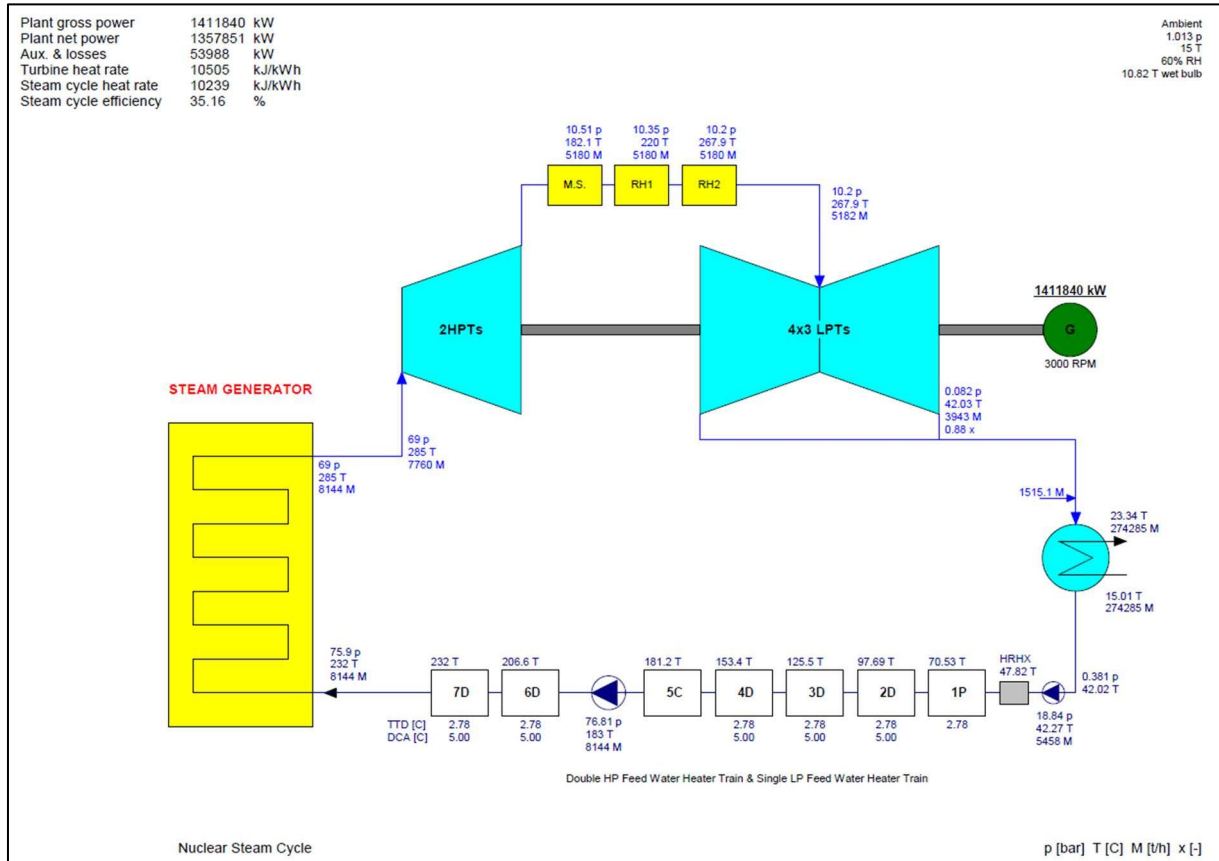

Figure 25 Steam diagram of the APR-1400 unit

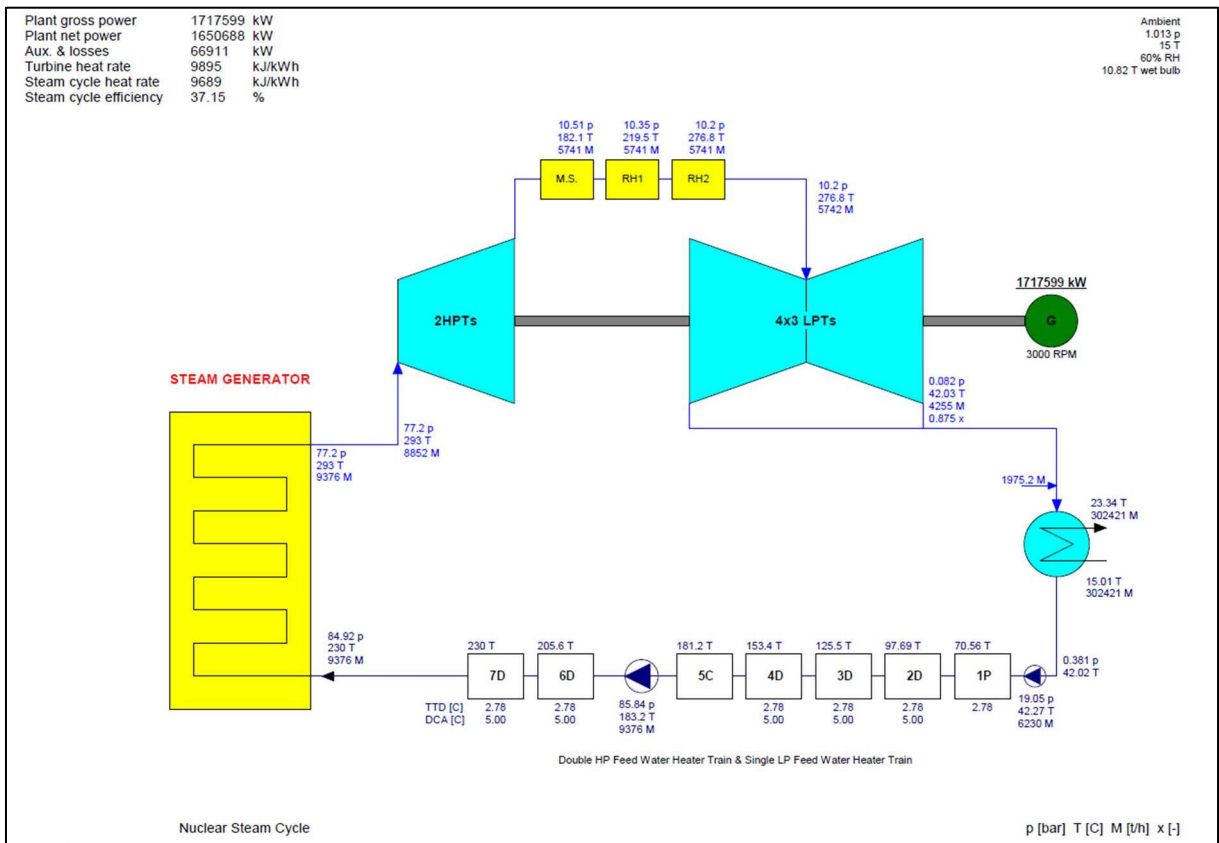

Figure 26 Steam diagram of the EPR-1600 unit

4.3. Recommendation of the reactor type (nuclear power plant) selected for further analysis

Based on an analysis of available materials and data obtained, it was decided that further work would be based on AP1000 reactor nuclear power plant technology. The choice of the AP1000 power plant is mainly due to the site conditions and the possibility of generating electricity at a similar level to that generated by the coal-fired units to be replaced. The overall dimensions of all power plant buildings and dedicated cooling towers initially allow for the location of two AP1000 units in the site under consideration, while maintaining the necessary auxiliary infrastructure, roads, safety zones, etc.

5. Description of the adopted solution

5.1. General scope of dismantling works

The project assumes that, for the retrofit with Generation III/III+ reactors, no major technological components of the power plant in question will be retained. For this reason, the scope of dismantling and demolition works will cover the entire infrastructure of the 200MW and 500MW units, with minor exceptions such as the power output system or hydrotechnical equipment/structures of the cooling water system, e.g. water intake and discharge channels, suction and discharge pipelines, etc. The above-mentioned power and hydrotechnical infrastructure will probably require reconstruction or adaptation to the requirements to ensure the safe operation of the nuclear power plant.

The sketch below shows the area of the coal-fired power plant infrastructure designated for demolition and development for two new nuclear power plant units.

The main facilities of the 200MW (1-8) and 500MW (9-10) units subject to demolition and/or site clearance for construction:

- Unit transformers
- Boiler house
- Engine room
- SCR installation for NO_x reduction
- Wet flue gas desulphurisation system consisting of:
 - Flue gas duct system with booster fan
 - Lime slurry generation system
 - Absorber
 - Gypsum dewatering system
 - Wastewater treatment system
- Flue gas discharge system (electrostatic precipitators, flue gas ducts, chimneys)
- Coal yard and coal feeding system



Figure 27 Location of the main power plant facilities

5.2. Recommendation of the type of cooling system selected for further analysis

A comparative analysis of cooling systems presented in section 3.3 shows that the best solution in terms of safety and environmental impact is a closed cooling system using a cooling tower. The most important advantages of constructing a cooling tower are independence from the hydrothermal conditions of the river, which affects the safety of the power plant and reactor, and a significant reduction in the facility's impact on the natural environment, mainly the Vistula River. Water intake from the river for the purposes of replenishing the cooling system and the steam-water system of the two AP1000 units of the nuclear power plant is approximately 2-3% of the volumetric flow rate of the current water intake for through-flow cooling of the existing 500 and 200MW coal-fired units.

5.3. Modifications to the existing open-circuit cooling system

The use of a closed-loop cooling system necessitates the reconstruction of the existing cooling water supply and discharge system. It is proposed that the existing channel supplying cooling water to the water intake will be retained. Due to the reduced amount of water intake, it will be necessary to install new pumps in the river water intake and to consider abandoning the intake de-icing system. For one nuclear power plant unit, it is assumed that the intake will be equipped with a new pump system configured as 3x50%. The capacity of each pump will be approximately 2,100 m³/h. For safety reasons or due to the manufacturer's specific requirements and solutions, this system may be expanded with an additional emergency pump.

The capacity of the new pumps will be determined by the water demand for the cooling system replenishment, desalination of water in the closed-loop cooling system, and water intake for the production of demineralised water. Cooling system replenishment is mainly due to water losses caused by evaporation and the entrainment of water droplets in the cooling tower.

Due to the small amount of water discharged from the desalination process, it is proposed to construct a new discharge pipeline and to decommission the existing discharge channels designed to discharge water from the current open cooling system.

5.4. Development area

For two identical nuclear units, the plan proposed would be to use the space currently occupied by the eight adjacent, currently operating 200 MW coal-fired units and two 500 MW coal-fired units. The first nuclear unit is planned to be built in the area occupied by 200MW units 1–7. The construction of the second nuclear unit is planned to be located in the area of the 500MW units, i.e. units 9 and 10, and the directly adjacent 200MW unit 8. The sketch below shows an example of the preliminary layout of the necessary components of a nuclear power plant unit.

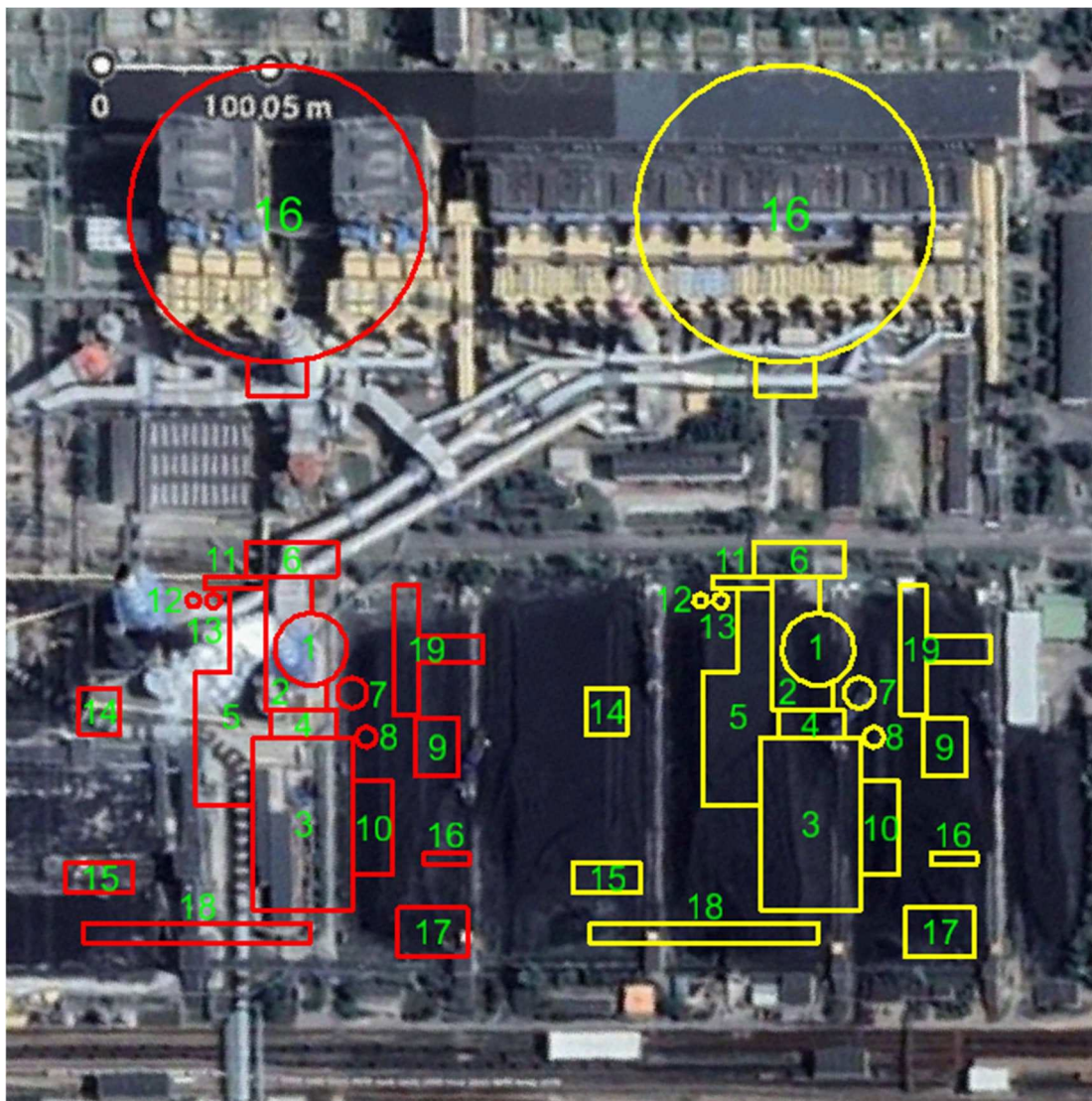

Figure 28 Building area of two nuclear blocks with AP-1000 reactors

The main components of a nuclear power plant can be divided into three basic areas: the nuclear island, the turbine island, and a number of ancillary installations.

The main facilities of a nuclear power plant include:

- Reactor building (safety enclosure + shielding building) (1)
- Auxiliary building (2)
- Machine building (4)
- Reactor support building (3)
- Radioactive waste building (5)
- Diesel generator building (14)
- Diesel fuel tanks for the generator (15)
- Circulating water system coolers (8)
- Fire water pumping station and fire water tanks (10)
- Condensate tanks (7), demineralised water tanks (11), boric acid tanks (12), water tanks for passive cooling of the containment (6)
- Auxiliary water storage tank for the passive cooling system of the reactor containment (9)
- Container platform for the transport of spent fuel (13)
- Cooling tower (16)

5.5. Preliminary technical description of the selected reactor

The reactor building consists of the reactor containment and the shielding (containment) building. The shielding building surrounds the containment. Both buildings are mounted on a common foundation slab set below the ground level of the power station. This configuration of the reactor building provides the necessary protection for the equipment located inside the reactor containment. Another important function of both buildings is related to the passive reactor cooling system.

The primary function of both buildings is to ensure the safe operation of the power plant by:

- containing radioactive substances during normal operation and in emergency conditions,
- protecting the reactor against external natural and human hazards,
- containment of ionising radiation during normal operation and in emergency conditions.

The safety enclosure is a hermetically sealed cylindrical vessel with all equipment inside. It prevents the release of radioactive substances into the environment and is an integral part of the passive cooling system. The passive cooling system is designed to remove sufficient energy from the containment in the event of a failure, and prevent the design pressure from being exceeded.

The containment building is a concrete structure that surrounds the containment vessel. It provides effective and sufficient protection for the containment vessel against external factors. Its design is engineered to withstand the impact of a large passenger aircraft. The containment building is also part of the passive cooling system. In the event of a failure and the release of a large amount of energy into the containment vessel, the containment building ensures natural circulation of cooling air. The upper part of the building also houses a water tank for emergency cooling of the containment vessel.

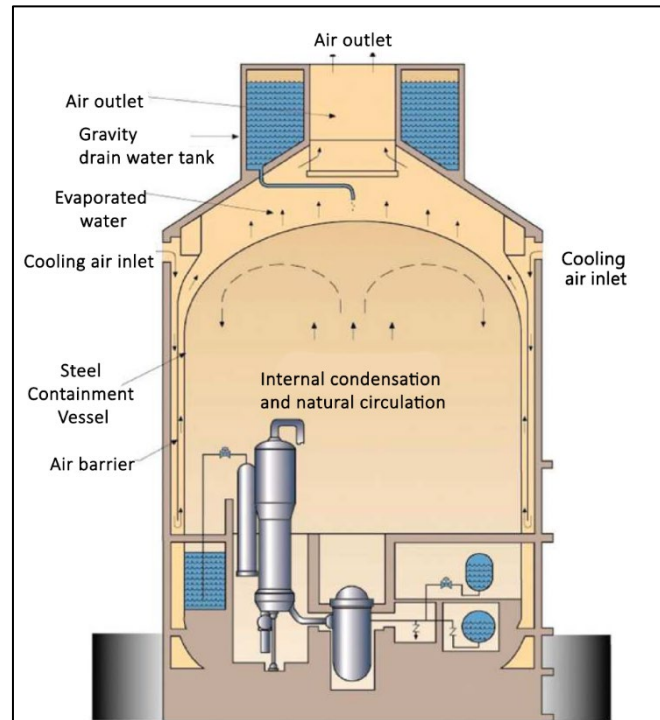

Figure 29 Reactor building

The machine room building, which houses the main equipment related to the turbine set, is not related to the safety of the facility. It is built on a separate foundation and adjoins the auxiliary building and the reactor support building. It provides protection against external conditions and ensures adequate thermal and acoustic insulation for the equipment installed inside it.

The engine room building houses:

- steam turbine
- generator
- feedwater system
- fresh and superheated steam system
- process water system
- condensate system
- power conversion cycle auxiliary devices
- other auxiliary systems
- electrical systems
- make-up water treatment system

The part of the machine room building located closest to the reactor will house the technological equipment related to the reactor.

The auxiliary building is divided into two parts. The first part is exposed to radiation, while the second part is not normally exposed to such radiation. The primary function of the building is to provide protection for safety-related equipment located outside the reactor building against the potential consequences of an internal or external event. The building also provides protection for the radioactive equipment and devices located within it. The building houses, among other things, a control room and control and power supply systems, nuclear fuel storage and radioactive waste processing areas, mechanical equipment, and the main steam and feedwater valves.

The reactor support building consists of several structures and includes areas that are both controlled and uncontrolled in terms of radiation exposure. The main building is the primary entrance for nuclear power plant personnel and provides the necessary access for staff and equipment to the nuclear island area. The buildings also house, among other things, a laboratory, staff and office facilities, electrical power systems, auxiliary diesel generators, a technical support centre, workshops and various heating, ventilation and air conditioning systems. The workshop is equipped with decontamination equipment, including portable units that can be used throughout the entire nuclear island.

The radioactive waste building includes facilities and equipment for sorting and storing various types of radioactive waste prior to further processing. The building also houses mobile waste processing equipment and a dedicated, separate area for the short-term storage of transport containers for processed solid fuel. The waste building does not contain any equipment related to the safety of the facility.

Basic functions of the radioactive waste building:

- Shipping contaminated clothing for off-site processing
- Processing and packaging of dry waste
- Dispatch of hazardous/mixed waste for off-site treatment
- Processing of chemical waste
- Collection and storage of empty waste containers
- Storage and loading of packaged waste for dispatch

The radioactive waste building also allows for the temporary storage of other categories of industrial waste.

The diesel generator building is located at a distance from the nuclear island buildings, and is set on a separate foundation. The location of the building will ensure a safe and reliable emergency power supply to the nuclear power plant in the event of disruptions to the primary power supply. The building houses two identical, backup, modular diesel-powered generators. The generators are separated from each other by a three-hour fire-resistant wall. In addition to the generators themselves, the building will also house power conversion cycle auxiliary equipment and devices, as well as the HVAC systems. This building is not related to the safety of the facility. At a certain distance from the generator building, there are two diesel fuel tanks with pumps, a tanker unloading bay and other auxiliary installations.

5.6. Electrical system for auxiliary power supply

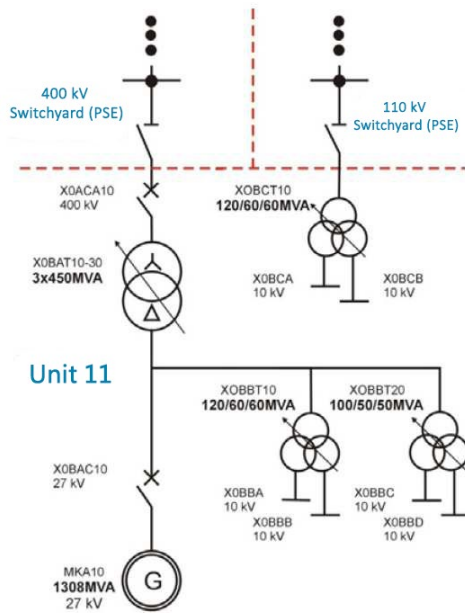

The auxiliary power supply for the new unit may look as shown in the diagram opposite (example from unit No. 11).

The primary power supply will be provided by tap-off transformers powered from a busbar bridge leading from the generator at a voltage of, for example, 27 kV. The size of the units must be selected according to the power demands of the 10.5 kV auxiliary switchgear – marked BBA/B/C/D. The 27/10.5 kV transformers will be three-winding, three-phase.

The backup power supply will be provided by a system of three-winding, three-phase transformers from the existing 110kV network. Transformer ratio 110/10.5kV.

The voltage level for internal power supply and connection to the Transmission System Operator's network requires consultation with the Operator and obtaining the connection conditions from them.

Each section of the 10.5kV switchgear for own needs will be supplied from three sources:

1. Primarily from a tap-off transformer - BBT
2. Backup from a 110/10.5kV transformer – BCA
3. Reserve power from another source, e.g. a power generator.

Currently, the existing units 1-11 are powered by 110 kV.

5.7. Power output

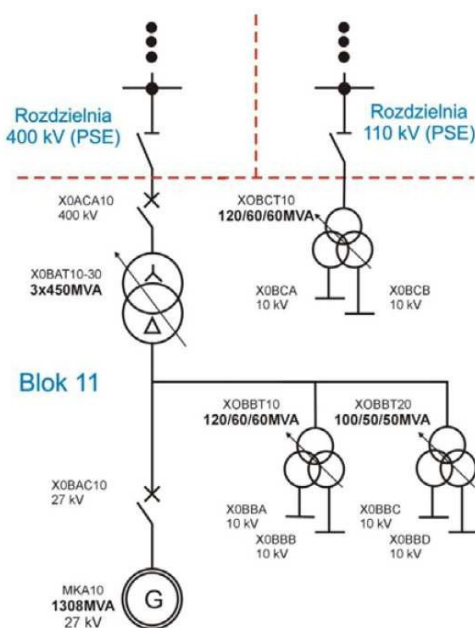

For units with a power output capacity exceeding 1000 MVA, it is recommended to use single-phase transformers (due to their size) in a configuration similar to that used in Koziencice for Unit 11.

Power is supplied via a busbar system connected to a generator circuit breaker (e.g. ABB HEC type) and then via a busbar bridge to the bay equipped with three single-phase unit transformers. From the transformer, power will be supplied to the Koziencice substation via an overhead line at a voltage of 400kV. Power transmission from the unit to the national power system ('krajowego systemu elektroenergetycznego' - KSE) requires obtaining connection conditions from the Transmission System Operator ('Operatora Systemu Przesyłowego' - OSP) on which the unit can be connected to the grid.

5.7.1. Legal Framework

In accordance with the applicable Energy Law (Journal of Laws 2024.0.266), an entity applying for connection to the grid must submit an application for determining the conditions for connection to the grid, hereinafter referred to as the "Connection Conditions", to the energy company to whose grid it is applying for connection, attaching the relevant documents and paying an advance towards the grid connection fee in the amount of PLN 30 (~\$7.5) for each kilowatt of connection capacity specified in the application for the determination of the connection conditions. The amount of the advance payment may not exceed the amount of the anticipated grid connection fee and may not exceed PLN 3,000,000 (~\$750,000).

In the case of equipment, installations or networks connected directly to the power grid with a rated voltage higher than 1 kV, an expert report on the impact of such equipment, installations or networks on the electricity system shall be prepared.

The electricity transmission company is obliged to conclude a connection agreement with the entity applying for connection to the grid.

The connection conditions shall specify the investment obligations of each party, including technical parameters, property boundaries and electricity billing arrangements.

If an electricity company refuses to conclude a grid connection agreement, it is obliged to immediately notify the President of the Energy Regulatory Office and the interested party of the refusal, stating the reasons for the refusal.

New nuclear units will be classified as type D generating units (power above 75 MW and connection voltage above 110 kV).

Journal of Laws 2024, item 412

ANNOUNCEMENT BY THE SPEAKER OF THE SEJM OF THE REPUBLIC OF POLAND
dated February 26, 2024

Regarding the publication of the consolidated text of the Act on the preparation and implementation of investments in nuclear power facilities and accompanying investments.

The requirements for connecting generating units to the grid are specified in the network code (Commission Regulation (EU) 2016/631 of 14 April 2016 establishing a network code on requirements for grid connection of generators - NC RfG)

5.7.2. Block transformers

Given the planned power output, it is recommended for economic and practical reasons to use single-phase power output transformers³⁴. Unit No. 4 is a standby transformer:

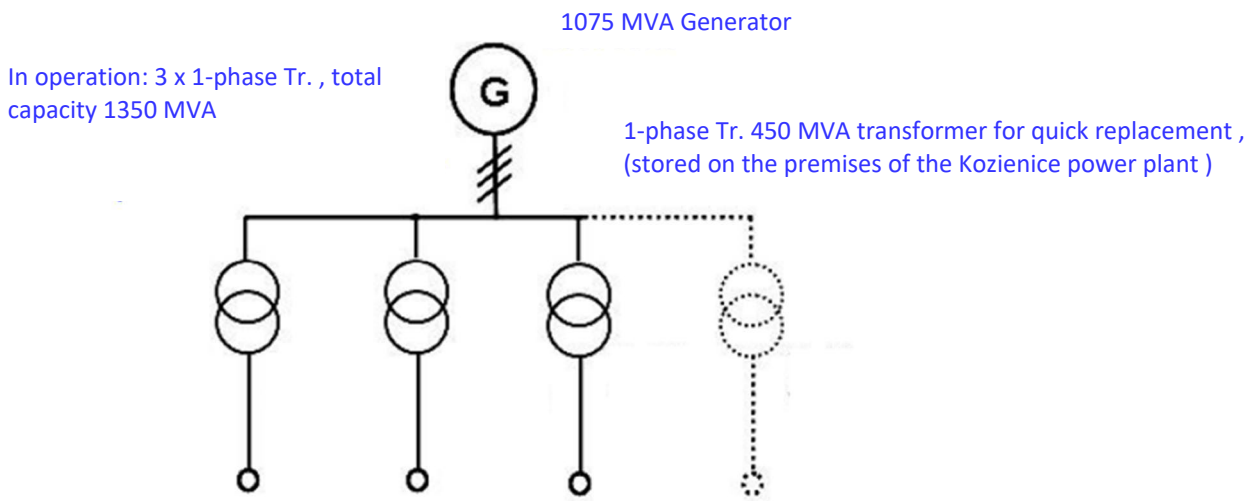

Delivering and installing these three-phase units is logistically difficult due to their weight and dimensions. The existing infrastructure and the associated transport of such large units pose a challenge. Examples of the dimensions and weight of three-phase units.

Table 14 Examples of dimensions of three-phase units

Transformer Power / Capacity	Transport Length	Transport Width	Transport Height	Transport Mass (without oil)	Total Mass
1000 MVA	15m	4m	5m	390 ton	485 ton
1200 MVA	17m	4.5m	5.5m	490 ton	630 ton
Dimensional limits for rail transport within the country	14m	3.5m	4.8m	Single-phase transformer 200 ton 265 ton	

The table below shows the construction costs, expressed as a percentage, for a three-phase unit with a three-phase reserve, and three single-phase units, with a single-phase reserve. The cost of constructing a 3-phase unit was taken as a benchmark.

Table 15 Comparison of transformer manufacturing costs

Comparison of transformer manufacturing costs (excluding transport costs)			
Transformer Power MVA	Block without reserve	Transformer Power MVA	Block with reserve
1 x 1200 3-phase Tr.	100%	2 x 1200 3-phase Tr.	200%
2 x 600 3-phase Tr.	151%	3 x 600 3-phase Tr.	227%
3 x 400 1-phase Tr.	141%	4 x 400 1-phase Tr.	188%

³⁴ Study by ABB & Aleksander Gul, "Modern ABB solutions for power output for 1.0 GW nuclear power plant units" – („Nowoczesne rozwiązania ABB dla wprowadzenia mocy dla bloków Elektrowni Jądrowych o mocy rzędu 1.0 GW”)

The four single-phase units currently operating at the Kozenice Power Plant were cheaper than two three-phase units.

Basic technical data of the transformer:

Rated power:	450MVA
Voltage ratio:	425/ $\sqrt{3}$ / 27 kV
Rated current:	1834 / 16,667 A
GN insulation level:	Li 1300 / AC 570 kV
DN insulation level:	Li 170 / AC 70 kV
Connection group:	YNd11 for 3 units).
Cooling type:	ODAF (oil-cooled radiators with forced circulation)

5.7.3. Block transformer bays

To facilitate power transmission and interconnection with the National Grid, it is proposed to construct bays for power transmission transformers.

An example of a block field topology is shown below:

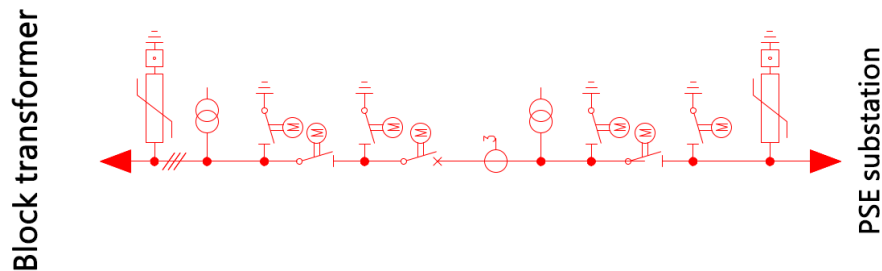

Figure 30 Example block bay topology

Proposed block field configuration

Example equipment in order from the block transformer side:

- surge arresters – voltage transformers – isolator with two earthing blades – circuit breaker – current transformers*
- voltage transformers* – isolator with two earthing blades – surge arresters

* Instead of separate current and voltage transformers, use a current-voltage (combined) transformer

5.7.4. Power Transmission lines

The existing overhead lines have been in service for many years. Despite regular inspections and maintenance, they are likely to show significant signs of wear and tear. This is because the location of the lines may not be suitable for power transmission, nor may they be technically adapted for this purpose. Changing the technical parameters would require administrative decisions and thus bringing them into line with current standards and environmental regulations. Their use for power transmission from a nuclear power station is not envisaged.

The new lines are to be constructed as overhead lines and/or underground lines, or as a combination of overhead lines and underground lines.

The parameters of the power transmission lines must correspond to those of the nuclear unit and meet the regulatory requirements and technical standards applicable at the time of their construction.

5.7.5. Expansion of the Kozenice power substation

Power infrastructure, including power stations and substations operating at voltages up to 400 kV, are technologically very well-established solutions with a wide market of suppliers offering a variety of technological solutions. In the case of this type of infrastructure, it is difficult to identify technological limitations that would prevent expansion, and any limitations are related to costs and implementation time. In the case of the project covered by this study, the implementation time for nuclear reactors is significantly longer than for typical grid investments in substation modernisation. Therefore, no risk related to the inability to expand the station is anticipated.

The nearest substation that potentially capable of accepting the generated power is the 400/220/110 kV Kozenice substation. Currently, the infrastructure of this substation potentially allows for the connection of a new unit line to the 400 kV switchyard.

If this plan is implemented, the operating substation will have been in service for many years and it should be assumed that it will require modernisation, in particular the 220 kV and 110 kV switchyards, which will need to be rebuilt in order to adapt to the new conditions.

Another important issue affecting the expansion of the substation will be the implementation of the schedule presented in section 3.1.1 concerning the decommissioning of the power plant's coal-fired units.

There are technical possibilities for the expansion/reconstruction of the station, and the only limitations are the costs and time required for implementation.

5.8. Power control system of a nuclear power plant

In PWR reactors, power adjustments are mainly achieved by changing the position of the control rods, and precise control of the reactivity in the reactor core is achieved by alteration of the concentration of boric acid in the primary coolant circuit.

In third-generation nuclear power plants, power changes from 100% P_{NOM} (P_{NOM} - Nominal Power) to 25% P_{NOM} are taken into account from the very beginning of the design process. For example, for the EPR reactor, two load following profiles have been designed:

- Load following within the range of 60% to 100% P_{NOM} at a rate of 5% P_{NOM}/min (with fuel burn-up to 80%),
- Load following within the range of 25% to 60% P_{NOM} at a rate of 2.5% P_{NOM}/min .

In third-generation nuclear power plants, power changes from 100% P_{NOM} to 25% P_{NOM} are taken into account from the very start of the design process. New nuclear power plants can vary their power output between 1260 MW and 630 MW at a rate of approximately 63 MW/min. As the figure shows, this flexibility is superior to that of coal-fired or gas-fired power plants.



Figure 31 Comparison of load (power) response rates in different types of grid-connected power plants

As shown in the figure, the time intervals during which the power of grid-connected power plants can be adjusted are similar. A nuclear power plant can change its output by 630 MW in 10 minutes, a coal-fired power plant by 480 MW in 12 minutes, and a CCGT (combined cycle gas turbine) power plant by 500 MW in 21 minutes. This gives power change rates of 63 MW/min, 26 MW/min and 38 MW/min, respectively.

As described above, nuclear power plants can not only operate in a load-following system, but they can do so more effectively than coal and gas power plants.

5.9. Civil engineering and road works

- Description of geological and engineering conditions

In accordance with section 3.7.4 of this study, based on publicly available soil test reports, it is concluded that the area in question contains moderately compacted fine and medium sands. The groundwater level is ~102 m above sea level (~-5.30 m).

Prior to commencement of works, a detailed ground investigation will be required in accordance with the Regulation of the Minister of Transport, Construction and Maritime Economy of 25 April 2012 on the determination of geotechnical conditions for the foundation of building structures and the Regulation of the Council of Ministers of 10 August 2012 on the detailed scope of the assessment of land intended for the siting of a nuclear facility, cases precluding the possibility of deeming the site to meet the requirements for the siting of a nuclear facility, and on the requirements concerning the siting report for a nuclear facility

- Construction site facilities

The construction site facilities will consist of a number of temporary structures used for the construction of the power plant. The main structures include:

- Staff and office buildings for employees
 - Gatehouses
 - Concrete batching plants
 - Warehouses and storage yards
 - Prefabricated component assembly halls
 - Workshops
 - Electrical substations
 - Waste management facilities
 - Temporary roads
- Description of buildings and structures

The Westinghouse AP1000 Plant

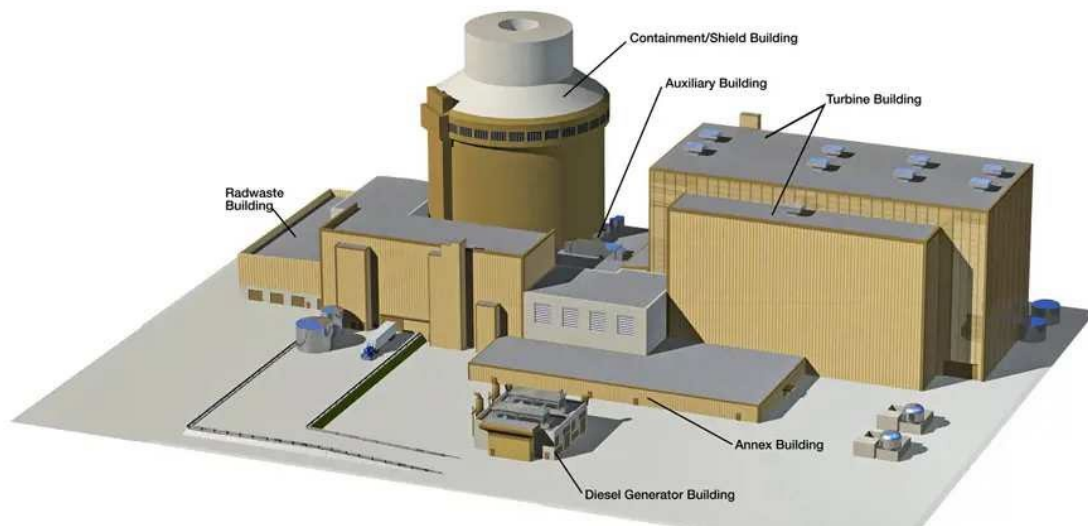

Figure 32 Layout of the main buildings of a nuclear power plant based on the AP-1000 reactor

In accordance with section 5.4, the following structures are considered to be essential power plant facilities:

- Reactor building

The AP1000 reactor building has a layered structure comprising a steel containment vessel, an external reinforced concrete shell and a passive cooling system. The steel tank (60 m high, 4.5 cm thick) surrounds the reactor and isolates it in the event of a failure. The reinforced concrete load-bearing shell protects against radiation and external damage. A cooling water tank is located at the top, with water flowing down by gravity, supporting passive cooling. The foundations are constructed as a massive reinforced concrete slab founded on piles, integrated with the IRWST tank. The interior consists of prefabricated technical levels. The entire structure is designed to be resistant to aircraft impact and to meet biological and chemical protection standards.

- Auxiliary building

The auxiliary building is a reinforced concrete structure with high seismic resistance, situated adjacent to the reactor building. It houses the reactor's auxiliary systems, including cooling, control and safety systems. Its design was conceived to provide radiation protection and ensure easy access to equipment. Inside, there are technical levels, control rooms, service areas, and ventilation and electrical installations. The building also provides an access route for fuel loading and unloading. Its design allows safety systems to operate even in emergency conditions and power failure.

- Machine room building

The machine room building is a technical hall housing a steam turbine, generator and condenser. Inside, there are overhead cranes for operating and maintaining the equipment.

- Reactor support building

The reactor support building is a reinforced concrete structure adjacent to the reactor building, housing auxiliary equipment and systems supporting the operation of the nuclear unit. It houses, among other things, water treatment systems, electrical, ventilation and control and measurement installations, as well as technical and service rooms. The structure was designed to provide high resistance to seismic loads and radiation. The building also houses service corridors, cable ducts and pipelines leading to the reactor building. The facility serves as a technical operational support centre, ensuring the reliable operation of key auxiliary systems.

- Radioactive waste building

The radioactive waste building is an isolated reinforced concrete structure designed for the temporary storage of low- and medium-level solid and liquid waste. It contains rooms for segregation, conditioning and packaging waste in appropriate protective containers. The facility is equipped with HEPA filtration ventilation systems, radiation monitoring, detection systems, and explosion and fire protection systems. The building meets strict radiological and environmental protection standards, and its design ensures leak-tightness and controlled storage conditions. Controlled access zones and technical rooms are also provided.

- Diesel generator building

The diesel generator building is a standalone reinforced concrete structure housing emergency power generators that provide power to key safety systems in the event of a loss of external power sources. Each unit is located in a separate, isolated zone, which minimises the risk of a common failure. The building is equipped with ventilation, cooling, fuel storage and automatic start-up systems. Emergency power is provided by at least two redundant generators located outside the reactor zone.

5.10. Technological assessments

Thermodynamic calculations for the selected AP-1000 nuclear reactor were performed using the STEAM PRO programme included in the ThermoFlow package. The model takes into account the technical parameters presented by the IAEA (International Atomic Energy Agency) and the results from the report on the previous DEsire project.

The model covers the steam section of the nuclear unit, without a detailed analysis of the reactor, which was treated as a back-box. Only the power level that the reactor transfers to the steam generator (which is then fed to the steam turbine), was taken into account. The unit operates at 100% condensation, and a cooling tower is used for cooling. Furthermore, based on an analysis conducted by the Silesian University of Technology, a solution with a series connection of condensers was used in the cooling system, as this reduces the amount of water in the cooling system required for the unit's operation. A detailed comparison of the condenser connecting mechanisms and their impact on the amount of cooling water can be found in the report from Task No. 3.

The figure below presents the results of model calculations for the steam section of the AP-1000 unit for the average annual ambient temperature (8.7°C) prevailing in Koźienice, determined on the basis of data from the Institute of Meteorology and Water Management (IMGW).

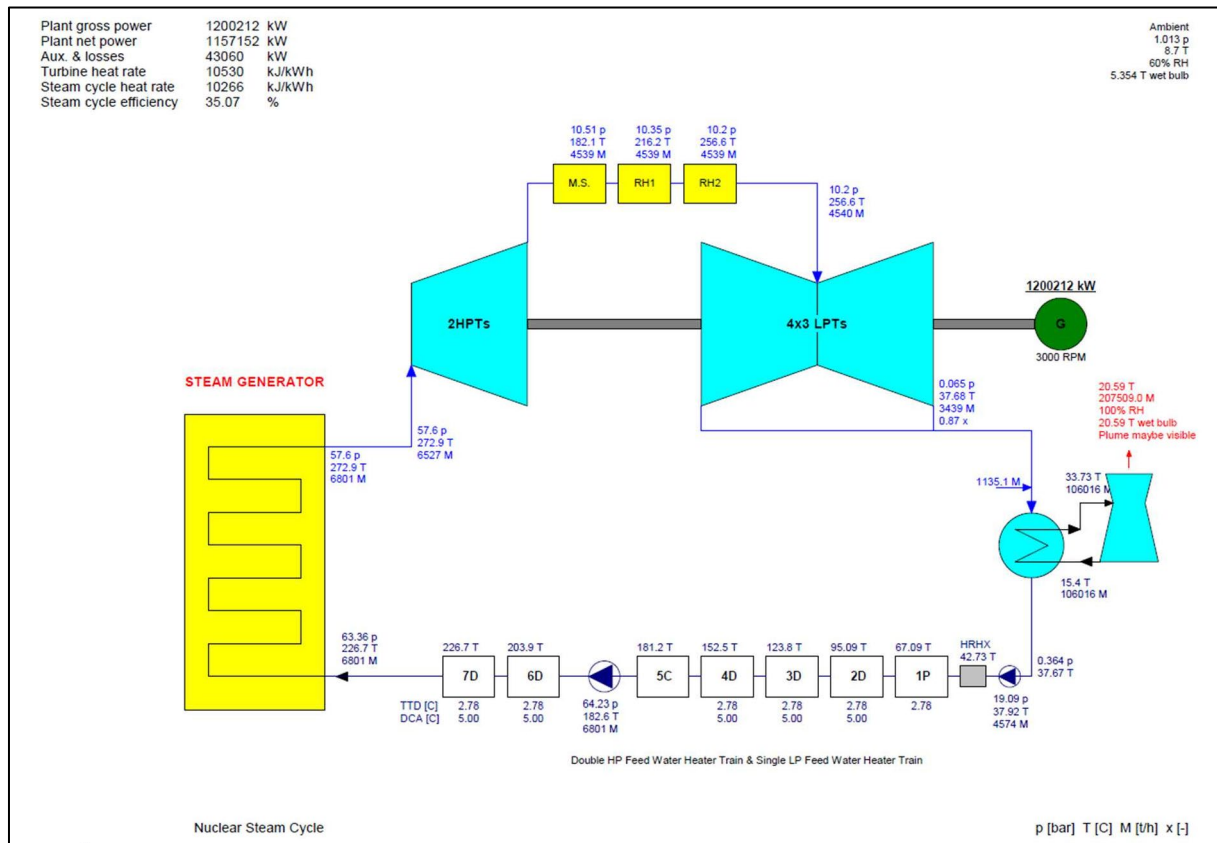

Figure 33 Steam diagram of the AP-1000 unit with cooling system

The table below summarises the main parameters of the AP-1000 unit modelled for the Koźienice location. The level of internal consumption has been increased compared to the above diagram, as it did not take into account other power plant equipment (apart from the steam section). In accordance with IAEA data, the level of internal consumption for the entire unit was set at 8.3%.

Table 16 Forecast parameters of AP-1000 units at the Kozenice site

Parameter	Unit	1 Unit	2 Unit
Reactor thermal power	MWt	3,423	6,845
Electrical power of the unit _{Gross}	MWe	1,200	2,400
Electrical power of the unit _{Net}	MWe	1,101	2,201
Unit efficiency _{Gross}	%	35.07	35.07
Cooling water flow rate	t/h	106,016	212,033
Cooling system water replenishment	t/h	2,829	5,658
DEMI (Demineralised) water replenishment	t/h	20.8	41.7
Nuclear fuel	kg	2.38	4.75

Nuclear fuel consumption was calculated based on a fuel burn-up rate of **60,000 MWd** per tonne of nuclear fuel. This fuel burn-up rate is typical for Generation III reactors as described in international literature. The calculated amount of uranium corresponds to a typical nuclear fuel fabrication process, where on average approximately 8.9 kg of uranium in the form of natural uranium oxide U_3O_8 is required per 1 kg of fuel.

The annual projected production and consumption of the analysed unit were calculated based on an energy availability factor of 84.2%. This is the availability factor presented in the Polish Nuclear Power Programme. This level is close to the European average (82.5%). Similar availability factors in recent years have been reported, among others, in the Czech Republic (83.9%) and Switzerland (83.4%), where there are relatively few reactors—6 and 4 respectively.

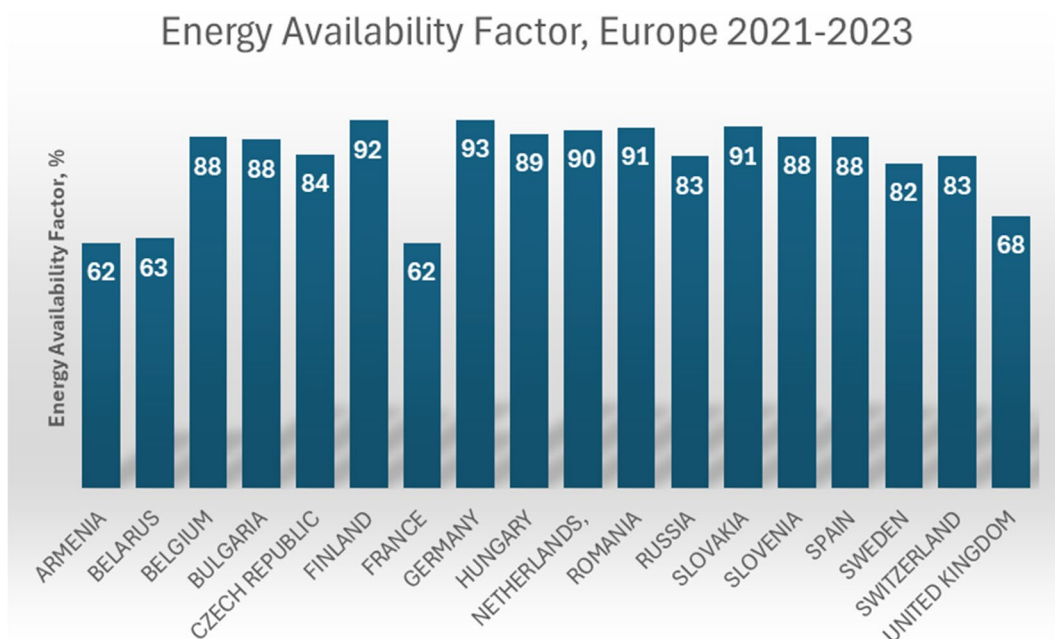

Figure 34 Nuclear reactor availability factor in Europe for 2021-2023 according to the IAEA³⁵

³⁵ <https://pris.iaea.org/PRIS/WorldStatistics/ThreeYrsEnergyAvailabilityFactor.aspx>

Table 17 Projected annual production figures for AP-1000 units at the Kozenice site

Parameter	Unit	1 unit	2 units
Availability (Capacity Factor)	%	84.2 %	84.2 %
Electricity production	GWh	8,853	17,705
Electricity sales	GWh	8,118	16,236
Nuclear fuel	tonnes/year	17.53	35.06
Cooling system water replenishment	thousand tonnes/year	20,867	41,735
DEMI (Demineralised) water replenishment	thousand tonnes/year	153.6	307.3

The figures presented will form the basis for an analysis of the economic efficiency of the project in question, which will be set out in the next section of this report.

6. Estimated capital expenditure

6.1. CAPEX structure

In international nomenclature, CAPEX investment costs are categorised into successive levels of complexity as follows:

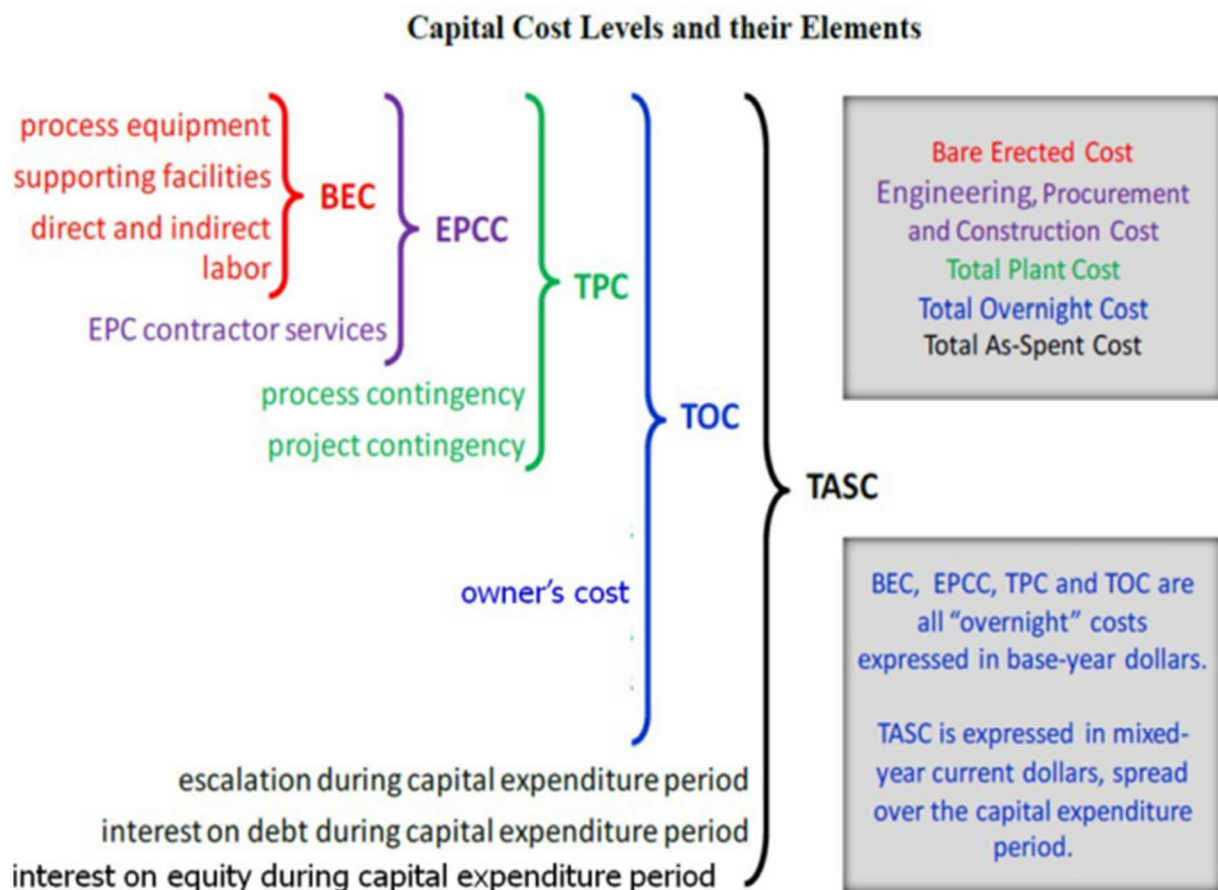

Figure 35 CAPEX structure

Data source: NETL, April 2011. Quality guidelines for energy systems studies: cost estimation

Methodology for NETL assessments of power plant performance. U.S. Department of Energy, National Energy Technology Centre, Pittsburgh, PA (Report DOE/NETL-2011/1455)

- BEC – these are so-called "hard, direct" costs, covering the supply of materials and equipment, labour costs and equipment costs.
- EPCC – these costs include BEC and the indirect costs of the EPC General Contractor (e.g. project coordination and management, certification and acceptance by Certification and Supervision bodies, preparation and maintenance of construction facilities, utilities during assembly, training, insurance, commissioning, etc.).
- TPC – these costs include EPCC and the contractor's risk costs and the financial reserves for the project.
- TOC – these costs include TPC and the Investor's costs (e.g. the Investor's implementation team, Contract Engineer services, warranty surveys, fees, expert reports, consultancy, insurance, etc.).

Note: all CAPEX cost groups listed above are expressed in fixed prices.

- TASC – these costs include TOC and are calculated in variable prices over the duration of the investment (from the construction period to commissioning), taking into account capital costs, interest and contract indexation.

This section of the study estimates the level of capital expenditure in the TOC cost group. Variable costs are included in the economic analysis presented later in this study.

6.2. Methodology

In order to determine the construction costs of two new AP-1000 units at the Koźienice Power Plant, the following steps were taken:

- The percentage breakdown of the costs for individual CAPEX elements was determined in accordance with industry studies;
- The unit construction cost of an AP-1000 unit under the Greenfield model was determined on the basis of press releases;
- The remaining costs associated with locating new AP-1000 units at the existing power plant were estimated, taking into account the resulting savings.
- An estimated CAPEX for the construction of two AP-1000 units at the Koźienice power plant was prepared.

6.3. Determination of the percentage distribution of capital expenditure

The table below presents a calculated possible distribution of CAPEX for individual cost categories of the AP-1000 unit for the Greenfield model, based on the document *"Investigating Benefits and Challenges of Converting Retiring Coal Plants into Nuclear Plants"* prepared by the U.S. Department of Energy and published in 2022.

Given that in the above-mentioned study, direct costs account for as much as 58% of Total Overnight Costs (TOC) costs, which in the opinion of the authors of this study is an overestimated value, it was decided to adjust the percentage distribution of capital expenditure based on the study *"Capital cost estimation for advanced nuclear power plants"* prepared by the Department of Nuclear Science and Engineering, Massachusetts Institute of Technology, USA, published in 2022.

The study referred to above mainly concerns PWR12 reactor units (the previous generation of AP-1000 units), and direct costs account for 48.91% of TOC costs. Despite the difference in technology, the division of costs between direct and indirect costs, according to the authors of the study, is closer to the truth than in the U.S. Department of Energy study.

In the study by the Department of Nuclear Science and Engineering, Massachusetts Institute of Technology, the share of indirect costs is 9.09 percentage points higher than in the study by the U.S. Department of Energy. Therefore, indirect costs were increased by 9.09 percentage points and direct costs from the U.S. Department of Energy study were reduced by 9.09 percentage points in order to maintain a proportional distribution of individual direct cost components for the indirect and direct cost groups. The results are presented in the table below.

Table 18 Percentage distribution of estimated investment capital expenditure for the AP-1000 unit

No.	Breakdown of TOC costs (1 AP-1000 unit) Greenfield	% share in investment capital
1	Initial fuel inventory	8.5 %
2	Owner's costs	11.8 %
3	Land and land rights	0.4 %
4	Auxiliary infrastructure	12.6 %
5	Reactor island	15.2 %
6	Turbine island	12.6 %
7	Electric island	4.2 %
8	Other apparatus and equipment	1.7 %
9	Condenser and heat dissipation system	2.5 %
10	Total indirect costs	30.4 %
11	Total share in investment capital	100.0%
12	Direct costs (Nos. 4-9) % TOC	48.9 %
13	Indirect costs (Nos. 1-3 and 10) % TOC	51.1 %

Data source: own calculations based on the document "Investigating Benefits and Challenges of Converting Retiring Coal Plants into Nuclear Plants"; U.S. Department of Energy; 2022 and "Capital cost estimation for advanced nuclear power plants"; Department of Nuclear Science and Engineering, Massachusetts Institute of Technology, USA; 2022.

6.4. Determination of the unit construction cost of an AP-1000 unit according to press releases

The study cited above, *'Investigating Benefits and Challenges of Converting Retiring Coal Plants into Nuclear Plants'*, shows the unit cost of constructing a PWR unit in the TOC cost category at **USD 4,572/kWe**. In the opinion of the authors of this study, this indicator may be an underestimate due to the rise in the prices of services and materials that has occurred in recent years as a result of the pandemic and the global geopolitical situation. Therefore, valuations from publicly available press releases are also cited below.

In December 2022, press reports appeared (<https://energetyka24.com/atom/analizy-i-komentarze/ile-zaplaci-polska-za-elektrownie-jadrowa-komentarz>) suggesting that the unit cost of constructing an AP-1000 unit may be approximately **USD 5,267/kWe** (PLN 31.26 billion/1 AP1000 unit at an exchange rate of PLN 4.7477/USD as at 28 October 2022).

However, the latest press release from April 2024 issued by PEJ (Polish Nuclear Power Company) (<https://www.money.pl/gospodarka/polski-atom-za-150-mln-zl-sa-tez-prognozy-ws-terminu-7018323225906112a.html>) mentions a cost of PLN 150 billion for three AP-1000 units, which gives a unit construction cost of **USD 10,000/kWe** for one AP-1000 unit. The article lacks a detailed explanation of the content of this indicator – whether it is a net or gross amount (including VAT), whether the prices are fixed or variable, whether it includes maintenance services, capital costs, etc. Depending on the interpretation of the above, in the opinion of the authors of this study, this indicator may range from **approximately USD 6,500 to USD 10,000/kWe**.

In turn, according to the latest study by the Massachusetts Institute of Technology, *"2024 Total Cost Projection of Next AP1000"*, the TOC costs for subsequent AP1000 units currently range between **\$9,300 and \$11,625/kWe**.

Taking the above information into account, it was decided to set **a unit rate of USD 10,000/kWe** for the purposes of this study. This is consistent with the press release issued by PEJ and falls within the range specified in the latest MIT study, *"2024 Total Cost Projection of Next AP1000"*.

The economic section presented later in this study includes a sensitivity analysis of the results to the level of CAPEX, which covers possible positive/negative deviations from the assumed level of CAPEX.

6.5. Determination of additional costs and savings related to the location of the planned investment

The following table presents additional costs (increasing the CAPEX value), savings (reducing the CAPEX value) and potential avoided costs resulting from locating the investment at the Koźienice Power Plant.

➤ Additional costs

The following additional and non-unit related costs must be incurred in order to carry out the investment at the Koźienice Power Plant

- Site clearance costs – demolition, dismantling and levelling (8 x 200 MW units and 2 x 500 MW units, including flue gas exhaust systems, the coal yard and transformer stations)

Additionally, these costs include the demolition of the weir on the Vistula River. These costs were not taken into account in the CAPEX calculation because they are costs that must be incurred by the Investor regardless of whether a new power unit will be built in the area of the existing power plant or not. In the absence of a new investment, the site must still be cleared and the installations dismantled at the end of the life cycle of the old coal-fired units.

These costs have been estimated at PLN 520 million net (~\$130 million net*).

- Costs of renovating intake points, discharge points and the cooling water pumping station building. These costs are estimated at PLN 2 million net (~\$500,000 net).
- Costs of power transmission to the Koźienice power station – 400 kV lines. These costs are estimated at PLN 8 million net (~\$2 million net).

➤ **Savings**

- Savings arising from the use of the intake, discharge and cooling water pumping station building – no need to construct these elements.

These savings are estimated at PLN 27 million net (~\$6.8 million net).

- Savings arising from the absence of a need to purchase land These savings have been estimated at PLN 364.9 million net (~\$91.2 million net).

➤ **Potential avoided costs** (a group falling outside the scope of the indicators for the construction of nuclear power units)

Below is a summary of the costs avoided, resulting from the use of the site at the Koźienice Power Plant, compared to a site not linked to the existing energy and logistics infrastructure. The potential avoided costs result from assumptions made by the authors of the study on the basis of other nuclear power unit locations with different site conditions. Therefore, average hypothetical estimates were used in this calculation.

- Cost of constructing a water intake and discharge channel to the river – 1 km of intake channel and 1 km of discharge channel assumed.

These savings were estimated at PLN 220 million net (~\$55 million net).

- Access road costs – 25 km assumed

These savings are estimated at PLN 125 million net (~\$31.3 million net).

- Costs of a single-track railway line – assumed to be 25 km These savings are estimated at PLN 625 million net (~\$156.3 million net).

- Costs of constructing the operator's power station in the case of investment locations far from existing stations, estimated by the Power Grid Operator; the investor may contribute to the costs depending on a bilateral agreement. The cost of such a station may amount to approximately PLN 80 million net (~\$21.9 million net).

*USD exchange rate at 1 USD = 4.0 PLN – see section 6.6

6.6. CAPEX estimate

➤ Assumptions

- All amounts given below are exclusive of VAT and are presented in fixed 2024 prices.
- The unit level of capital expenditure for the construction of the AP-1000 unit was estimated on the basis of press releases and industry publications presented in section 6.4. – it amounts to USD 10,000 net/1 kWe. The percentage breakdown of costs into individual groups was determined on the basis of information from industry publications.
- Elements outside the scope of the unit cost index for the construction of PWR-class units, as well as additional costs and savings, were estimated on the basis of publicly available market price bulletins for works and investment facilities published by such publishers as Bistyp and Sekocenbud, as well as price indices of B.S.P.i R Energoprojekt - Katowice S.A., developed through many years of experience in the design and estimation of the costs of installations similar in size and technical parameters.
- The following exchange rate was used for currency conversion: 1 USD = 4 PLN.
- AP-1000 unit capacity used for calculations: 1250 MWe (gross)
- This study is at the preliminary feasibility study stage. In accordance with the AACE International Recommended Practice classification system, the expected accuracy of the valuation range is presented in the table below:

Table 19 Classification of CAPEX estimation accuracy according to AACE International Recommended Practice

ESTIMATE CLASS	Primary Characteristic	Secondary Characteristic		
	MATURITY LEVEL OF PROJECT DEFINITION DELIVERABLES Expressed as % of complete definition	END USAGE Typical purpose of estimate	METHODOLOGY Typical estimating method	EXPECTED ACCURACY RANGE Typical variation in low and high ranges
Class 5	0% to 2%	Concept screening	Capacity factored, parametric models, judgment, or analogy	L: -20% to -50% H: +30% to +100%
Class 4	1% to 15%	Study or feasibility	Equipment factored or parametric models	L: -15% to -30% H: +20% to +50%
Class 3	10% to 40%	Budget authorization or control	Semi-detailed unit costs with assembly level line items	L: -10% to -20% H: +10% to +30%
Class 2	30% to 75%	Control or bid/tender	Detailed unit cost with forced detailed take-off	L: -5% to -15% H: +5% to +20%
Class 1	65% to 100%	Check estimate or bid/tender	Detailed unit cost with detailed take-off	L: -3% to -10% H: +3% to +15%

Cost Estimate Classification Matrix for Process Industries

which shows the accuracy of the valuation range between the concept stage and the actual feasibility study.

➤ **Calculations**

The total unit costs for two AP-1000 units were determined as follows:

USD 10 million/MWe x 1,250 MWe x 2 units = 10 x 1,250 x 2 = USD 25,000 million net

The dollar exchange rate according to the National Bank of Poland in 2024 fluctuated around PLN 4.0. For the purposes of this study, this standardised value was adopted.

After converting the above at a rate of 1 USD = 4.0 PLN, we obtain: 25,000 million USD

x 4.0 PLN/USD = **100,000 million PLN net**

Subsequently, the above cost was divided into individual components according to the assumptions set out in the preceding sections, based on industry data.

In the next step, additional costs were added, and savings resulting from the location of the facility on the Kozienice Power Plant site were deducted.

The results of the calculations are presented in the table below.

Table 20 Estimated construction costs for two AP-1000 class units at the Kozenice Power Plant

No.	Specification of works (2 x AP-1000 units)	% share in the index	Value in PLN million net	Value in USD million net
1	Initial fuel inventory	8.5 %	8,515.0	2,128.8
2	Other costs (ownership, transmission)	11.8 %	11,799.4	2,949.9
3	Land and land rights	0.4 %	364.9	91.2
4	Auxiliary infrastructure	12.6 %	12,649.1	3,162.3
5	Reactor island	15.2 %	15,179.0	3,794.8
6	Turbine island	12.6 %	12,649.1	3,162.3
7	Electrical island	4.2 %	4,216.4	1,054.1
8	Other apparatus and equipment	1.7 %	1,686.6	421.7
9	Condenser and heat dissipation system	2.5 %	2,529.8	632.5
10	Total indirect costs	30.4 %	30,410.7	7,602.7
11	Total indicative unit costs	100.0 %	100,000.0	25,000
12	Costs of power transmission to Kozenice Substation – 400 kV lines		8.0	2.0
13	Savings from the use of the existing intake, discharge and cooling water pumping station building, including the costs of necessary renovations		-25.0	-6.25
14	Savings due to no need to acquire land		-364.9	-91.2
15	Total investment expenditure		99,618.1	24,904.5

Source: own calculation

The above calculations do not include avoided costs, as they do not affect CAPEX, do not need to be incurred, and fall outside the scope of the nuclear reactor construction indicator; therefore they do not reduce the aforementioned costs.

However, the avoided costs represent added value in light of the investment's location at the Kozenice Power Plant. Their level varies greatly depending on the potential site of the nuclear power plant. Therefore, it is not possible to determine the exact savings they would yield, as such calculations can only be made in relation to another specifically identified site.

The table below presents avoided costs based on average, hypothetical estimate values:

Table 21 Potential avoided costs based on hypothetical cost estimates

No.	Potential avoided additional costs related to locating the investment on the site of the Kozenice Power Plant	Value in PLN million net	Value in USD million net
1	Costs of constructing a water intake and discharge channel to the river - 1 km of intake channel and 1 km of discharge channel assumed	220	55
2.	Costs of an access road - 25 km assumed	125	31.2
3.	Costs of a single-track railway line - assumed 25 km	625	156.2
4	Total potentially avoided costs	970	242.5

Data source: own calculation

6.7. Comparison of Greenfield vs. Brownfield

A comparison was made of the construction costs of two AP1000 units at the Kozenice site versus a Greenfield model. The results are shown in the table below:

Table 22 Cost comparison

No.	Specification of works (2 x AP-1000 units)	Brownfield Value in PLN million net	Brownfield Value in USD million net	Greenfield Value in PLN million net	Greenfield Value in USD million net
1	Preliminary fuel inventory	8,515.0	2,128.8	8,515.0	2,128.8
2	Other costs (ownership, transmission)	11,799.4	2,949.9	11,799.4	2,949.9
3	Land and land rights	0	0	364.9	91.2
4	Supporting infrastructure	12,649.1	3,162.3	12,649.1	3,162.3
5	Reactor island	15,179.0	3,794.8	15,179.0	3,794.8
6	Turbine island	12,649.1	3,162.3	12,649.1	3,162.3
7	Electric island	4,216.4	1,054.1	4,216.4	1,054.1
8	Other apparatus and equipment	1,686.6	421.7	1,686.6	421.7
9	Condenser and heat dissipation system	2,529.8	632.5	2,529.8	632.5
10	Total indirect costs	30,410.7	7,602.7	30,410.7	7,602.7
11	Savings from the use of the intake, discharge and cooling water pumping station building, including the costs of necessary renovations	-25.0	-6.3	0	0
12	Power connection costs, assumed to be 2 x 1 km for Greenfield	8.0	2.0	20.0	5.0
13	Costs of constructing a water intake and discharge channel to the river - assumed 1 km of intake channel and 1 km of discharge channel	0	0	220	55
14	Costs of the access road - 25 km were laid	0	0	125.0	31.3
15	Costs of a single-track railway line - 25 km assumed	0	0	625.0	156.3
16	Total investment expenditure	99,618.1	24,904.5	100,990.0	25,247.5

Data source: own calculation

As can be seen from the table above, Brownfield costs are approximately 1.4% lower than for the Greenfield option. However, it should be noted that there are also

two important aspects :

- social aspects, i.e. maintaining local jobs, retaining people with energy experience at the existing power plant and continuing the organisational culture of the energy company.
- infrastructural aspects, i.e. the use of existing energy infrastructure (lines and stations) and transport infrastructure (roads, railways), which would become redundant if the power plant were to be decommissioned.

7. Analysis of economic efficiency for the specified assumptions, supplemented by an analysis of investment risk (sensitivity analysis to changes in the legal and economic environment)

7.1. Subject, methodology and purpose of the analysis

A DCF economic model was prepared for the project in question, using the FCFE (free cash flow to the firm) formula. As part of the analysis, the LCOE indicator was calculated, which determines the minimum price of electricity that balances the production costs in a given type of generation unit. It is also the minimum price at which the sale of energy allows the investment to exceed the break-even point.

Standard profitability indicators such as NPV and IRR were not calculated because the LCOE indicator makes it easier to compare different technologies and does not require assumptions about future electricity prices. Forecasting energy prices 70-80 years into the future, given the current realities and changes in the markets, is subject to a large margin of error.

The LCOE [PLN/MWh] Levelised Cost of Energy indicator determines the average cost of producing 1 MWh of electricity, calculated according to the following formula:

$$LCoE = \frac{\sum_{t=1}^n \frac{(I_t + M_t)}{(1+r)^t}}{\sum_{t=1}^n \frac{E_t}{(1+r)^t}}$$

Figure 36 Formula for determining LCoE

where:

I_t – CAPEX investment expenditure in year t

M_t – OPEX costs in year t

r – pre-tax discount rate

E_t – heat production in year t

The economic analysis also includes an analysis of the sensitivity of LCoE to key variables in the economic calculation.

7.2. Assumptions

- The analysis period is 71 years, comprising:
 - Investment implementation period: 10 years, taking into account the postponement of the commissioning date of the second unit by 1 year
 - Operational period: 60 years
 - It is assumed that both nuclear units will be commissioned after 2040, one year after the other.
- The calculation is made on an annual basis, in net prices (excluding VAT) and in real terms (excluding inflation).
- CIT income tax rate – 19%
- RV – residual value calculated as the net value of fixed assets

7.2.1. Capital expenditure

Capital expenditure is presented in detail in Chapter 6. The table below shows the capital expenditure schedule for the unit, broken down into the Greenfield and Brownfield options.

Table 23 Schedule of capital expenditure in the Greenfield variant, PLN million net

Year	TOTAL	1	2	3	4	5	6	7	8	9	10	11
CAPEX – Unit 1	50,495	1,010	2,777	6,059	9,973	8,206	5,554	6,059	5,302	3,408	2,146	0
CAPEX – Unit 2	50,495	0	1,010	2,777	6,059	9,973	8,206	5,554	6,059	5,302	3,408	2,146
TOTAL CAPEX PLN million net	100,990	1,010	3,787	8,837	16,032	18,178	13,760	11,614	11,361	8,710	5,554	2,146

Table 24 Schedule of capital expenditure in the Brownfield option, PLN million net

Year	TOTAL	1	2	3	4	5	6	7	8	9	10	11
CAPEX – Unit 1	49,809	996	2,739	5,977	9,837	8,094	5,479	5,977	5,230	3,362	2,117	0
CAPEX – Unit 2	49,809	0	996	2,739	5,977	9,837	8,094	5,479	5,977	5,230	3,362	2,117
TOTAL CAPEX PLN million net	99,618	996	3,736	8,717	15,814	17,931	13,573	11,456	11,207	8,592	5,479	2,117

7.2.2. Discount rate

Pre-tax WACC discount rate in real terms equal to **6.98%**

$$WACC_{nom} = K_W * k_W * + K_O * k_O * (1 - T_c)$$

K_W – cost of equity (15.3%)

$$K_W = \text{Risk-free rate (5.24\% }^{36}) + \text{Market risk premium (5.15\% }^{37}) + \text{Project risk premium (2\%)}$$

k_W – equity capital share (30%)

³⁶ Announcement by the President of the Energy Regulatory Office; Q3 2024

³⁷ Damodaran – Equity risk premium Poland 01.07.2024

K_0 – cost of debt (7.24%)

$$K_0 = \text{Risk-free rate (5.24\%)} + \text{Debt margin (2\%)}$$

k_0 – proportion of debt (70%)

T_c – corporate income tax (19%)

$$WACC_{realny} = \frac{WACC_{nom} + 1}{CPI + 1} - 1$$

CPI – inflation over a 5-year period (assumed to be 2.5%³⁸)

7.2.3. Exchange rates

The EUR/PLN exchange rate was adopted on the basis of data published on the website nbp.pl, "Macroeconomic forecasts by professional forecasters. Results of the NBP Macroeconomic Survey, March 2024 round," at 4.3 as the median of forecasts for 2024-2026, and was left unchanged until the end of the calculation period.

The National Bank of Poland (NBP) set the exchange rate of the US dollar (USD) against the Polish zloty (PLN) on Friday, 22 March 2024, at PLN 3.9928, which rounded to two decimal places gives a value of PLN 4.00/USD. According to other forecasts, including those by Bloomberg, a similar EUR/USD ratio will be maintained in the coming quarters, which is why analyses assume that this trend will continue.

Table 25 Exchange rate forecast

Currency	Unit	Value
US dollar	[PLN//USD]	4.0
Euro	[PLN/EUR]	4.3

7.3. Operating costs

$$OPEX = \text{variable OM cost} + \text{fixed OM cost per year}$$

The economic analysis covers the following operating costs:

- Fuel costs
- Waste disposal costs
- Water replenishment costs (for the cooling system and DEMI)
- Repairs and upgrades
- Property insurance
- Civil liability insurance for nuclear damage
- Property tax
- Costs of salaries and employee benefits
- Costs of future decommissioning of the unit (decommissioning fund)

³⁸ Inflation target of the National Bank of Poland and the Monetary Policy Council

7.3.1. Fuel costs

Fuel costs were calculated based on the volume of electricity generated, expressed in MWh. The annual output of the unit was assumed on the basis of technological balances from section 5.10. One unit, at the assumed base availability, will generate **8,852,666 MWh of electricity** annually.

The unit price of nuclear fuel according to various sources over the years is shown in the graph and table below.

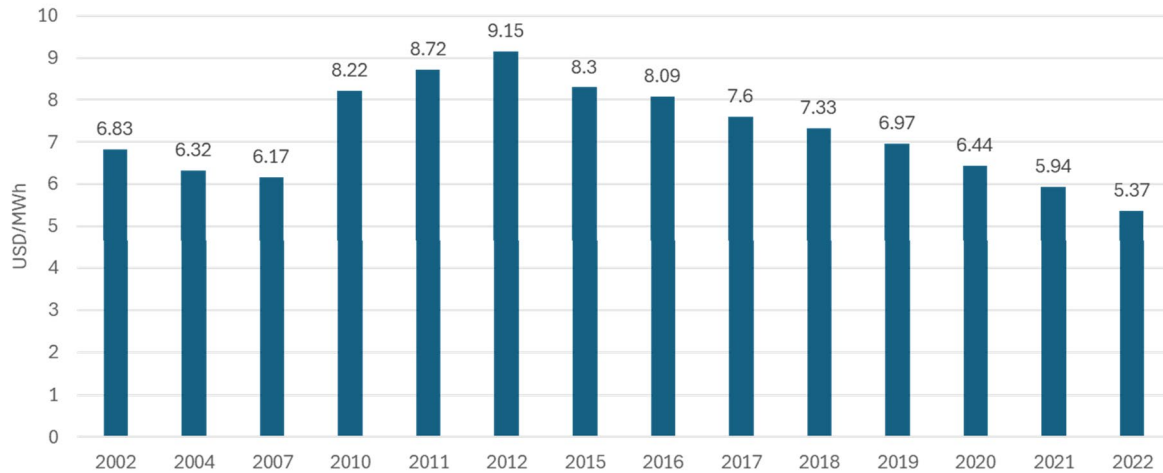

Figure 37 Nuclear fuel costs over the years

Source: NEI, Nuclear Costs in Context, 2023

Table 26 Sources of nuclear fuel prices

Other sources	Value	Unit/year
IAEA; Economic Assessment of the Long-Term Operation of Nuclear Power Plants	7.00	USD ₂₀₁₈ /MWh
MIT; Overnight Capital Cost of the Next AP1000	6.15	USD ₂₀₂₂ /MWh
MIT; 2024 Total Cost Projection of Next AP1000	6.25	USD ₂₀₂₃ /MWh

For the calculations, the unit cost of fuel expressed in USD/MWh was assumed, based on a study by the Nuclear Energy Institute⁽³⁹⁾ to be **5.37 USD/MWh** (taking US inflation into account, fuel costs will amount to USD 5.73/MWh). Ultimately, the annual fuel costs for a single unit will amount to approximately **PLN 203 million (~\$50.8 million)**.

7.3.2. Spent nuclear fuel disposal costs

The costs of fuel disposal were also calculated based on the amount of electricity produced. The unit rate was adopted in accordance with the following studies:

- A. Strupczewski, *Analysis and assessment of electricity costs from various energy sources in Poland (Analiza i ocena kosztów energii elektrycznej z różnych źródeł energii w Polsce)*, NCBJ, 2015.
- K. Kołacińska, R. Sasin, *Analysis of the costs and benefits of implementing nuclear energy in Poland (Analiza kosztów i korzyści wdrożenia energetyki jądrowej w Polsce)*, Energy Market, 2016.

where the rates are USD 2.33/MWh and EUR 2.17/MWh, respectively.

³⁹ Overnight Capital Cost of the Next AP1000; Koroush Shirvan; March 2022

A rate of **USD 3.53/MWh** (averaged value after indexation) was used for the analyses. This amount includes the removal, storage and disposal of spent fuel. Converted into annual values, the cost of fuel disposal amounts to approximately **PLN 125 million** per unit.

7.3.3. Water replenishment costs

Raw water and DEMI consumption was determined in section 5.10. A rate of **PLN 10.35/t** was used to calculate DEMI water costs, based on data received from ENEA.SA for unit 11 in Koźlenice.

For raw water, it was assumed that raw water for cooling system replenishment would be taken from the river. The unit rate for raw water was set at **PLN 1.5/tonne** based on the Council of Ministers Regulation on water abstraction rates⁴⁰, which also includes the costs of physical water abstraction from the river. The annual costs are as follows: approx. **PLN 1.6 million** per unit for DEMI water and approx. **PLN 31 million** per unit for raw water.

7.3.4. Costs of salaries and employee benefits

Nuclear energy creates more jobs than any other energy source. The standard number of people employed at a nuclear power plant (1 GWe reactor) ranges from 500 to 800 permanent employees for regular operation and maintenance.⁴¹ Other sources⁴² indicate a figure of 600 employees, but for AP-1000 units, in extreme cases, the number of staff can be reduced to around 400. Ultimately, the analysis assumed employment of **500 people** for each unit.

The gross remuneration of one person was assumed to be PLN 14,700 (\$3,675) per month, based on data on earnings in the ENEA SA group at the Koźlenice power plant. The level of social security and other benefits payable by the employer was assumed to be 21%.

The annual costs of salaries and employee benefits per unit amount to approximately **PLN 107 million (\$26 million)**.

7.3.5. Property insurance costs

Property insurance costs were assumed as a percentage of total capital expenditure at 0.323% per annum, which translates into approximately **PLN 161 million (\$40.3 million)** per unit. The insurance rate was assumed based on data from ENEA SA for unit 11 in Koźlenice.

7.3.6. Civil liability insurance for nuclear damage

Civil liability insurance costs are calculated based on the assumed maximum amount of insurance coverage for nuclear damage and a fixed percentage of that sum, paid annually during the operational period. The maximum amount covered by insurance is PLN 1,350 million (\$375.5 million) - (i.e. 300 million SDRs in accordance with the Atomic Energy Act) and the annual insurance premium (as a percentage of the maximum sum insured) is 0.25%. The final insurance premium, at the assumed exchange rate of SDR = PLN 5.28, is approximately **PLN 4 million (\$1 million)**.

⁴⁰ REGULATION OF THE COUNCIL OF MINISTERS of 26 October 2023 on unit rates for water services

⁴¹ <https://info.westinghousenuclear.com/poland/news-and-insights/kariera-w-przemysle-jadrowym>

⁴² Overnight Capital Cost of the Next AP1000: Koroush Shirvan; March 2022

7.3.7. Property tax

Property tax was calculated as a percentage of the value of buildings, which account for approximately 13% of total investment expenditure. Under current legislation, the tax rate on buildings is 2% per annum of the value of the buildings. Ultimately, the annual tax costs per unit amounts to approximately **PLN 130 million (\$32.5 million)**.

7.3.8. Renovation costs (unit maintenance)

Renovation costs were assumed on the basis of Total Generating Cost indicators presented in a study by the Nuclear Energy Institute ⁴³, which are divided into three components:

- Fuel – fuel cost
- Capital – capital expenditure, which includes the cost of spare parts, expenditure on upgrades and off-site infrastructure. Regulatory, ICT and maintenance costs.
- Operating – operating costs, which include the costs of materials and services, fuel management, external services, training and salaries.

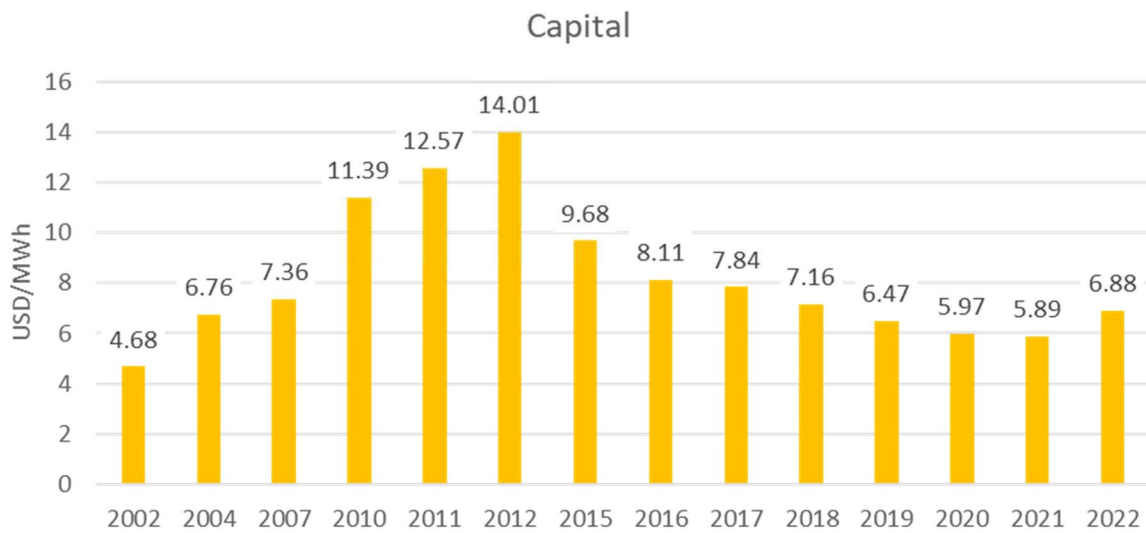

Figure 38 Unit capital costs

Source: NEI, Nuclear Costs in Context, 2023

⁴³ Overnight Capital Cost of the Next AP1000; Koroush Shirvan; March 2022

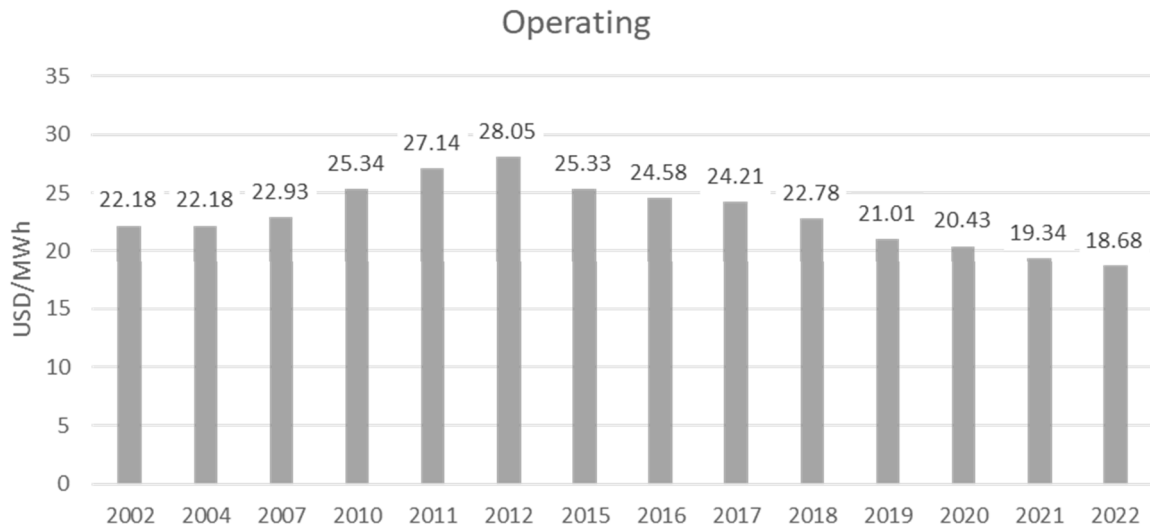

Figure 39 Unit operating costs

Source: NEI, Nuclear Costs in Context, 2023

Renovation costs were taken to include total capital expenditure and a portion of operating costs corresponding to the costs of external services. The total costs amount to USD₂₀₂₂ 12.75/MWh, which, after adjusting for US inflation, amounts to **USD 13.62/MWh**. The total annual costs of repairs and modernisation per unit amount to approximately **PLN 483 million (\$120.8 million)**.

7.3.9. Future decommissioning costs

Based on an IAEA study⁴⁴ estimates have been made for the future decommissioning costs of the facility, which will commence after the end of the unit's operation and will last six years. For this purpose, it was assumed that for each year of operation, an amount corresponding to the future decommissioning costs of the nuclear facility will be set aside in equal instalments. The total cost may amount to approximately 15% of the total capital expenditure. The annual allocation to the retirement fund for one unit will amount to approximately **PLN 125 million (\$31.3 million)**.

⁴⁴ Economic Assessment of the Long Term Operation of Nuclear Power Plants: Approaches and Experience; IAEA Nuclear Energy Series

The total annual operating costs for one AP-1000 unit were calculated at **PLN 1,369 million (\$342.3 million)**. The chart below shows the share of individual costs for one AP-1000 unit.

Figure 40 Annual operating costs for one AP-1000 unit

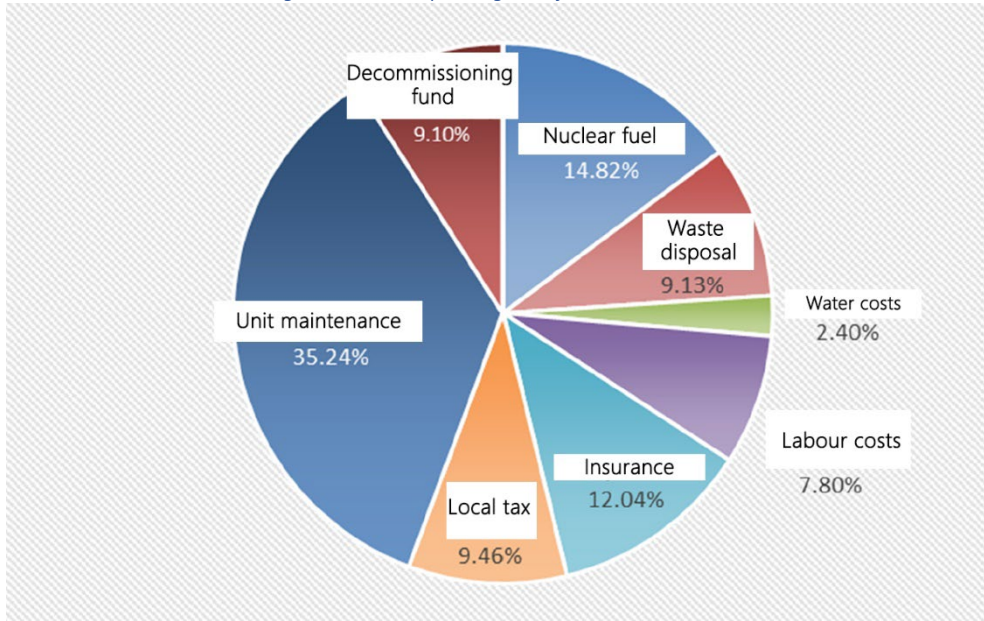

7.4. LCoE results

For the previously described capital expenditure and operating costs of the unit, assuming electricity production, the LCoE indicator was determined separately for each unit in the Brownfield and Greenfield options.

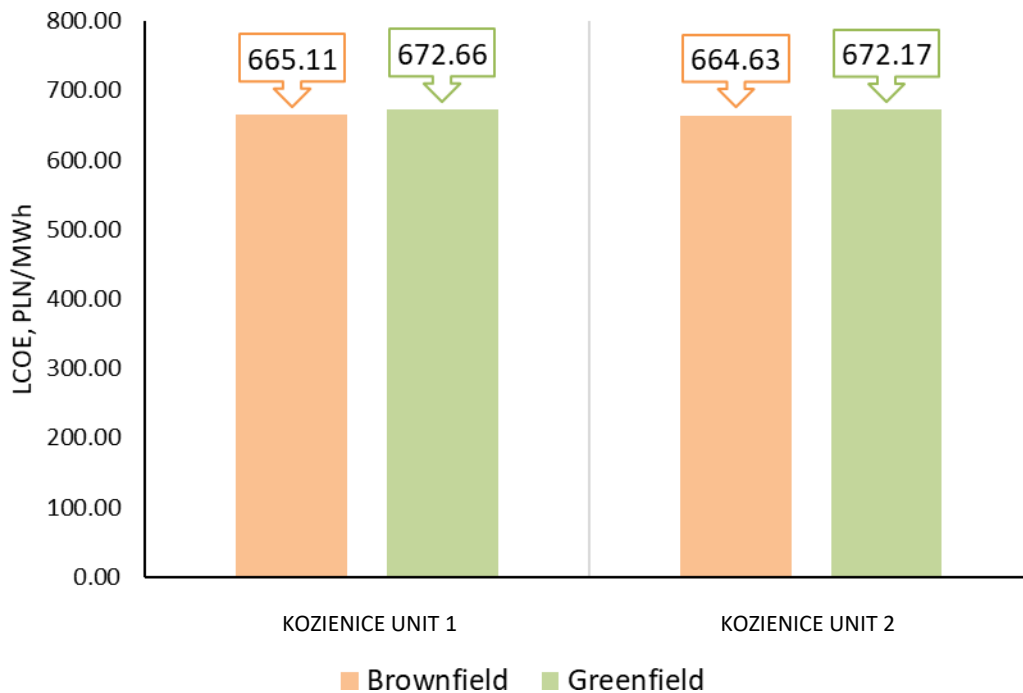

Figure 41 Comparison of Brownfield vs. Greenfield LCoE for both units

The difference in LCoE between the units in Kozenice results from the approach taken to calculate civil liability insurance for nuclear damage. The insurance is paid by the owner for the entire facility, rather than for individual units. In addition, the units have different start and end dates for their operational life. The LCoE structure for the Brownfield option is shown below.

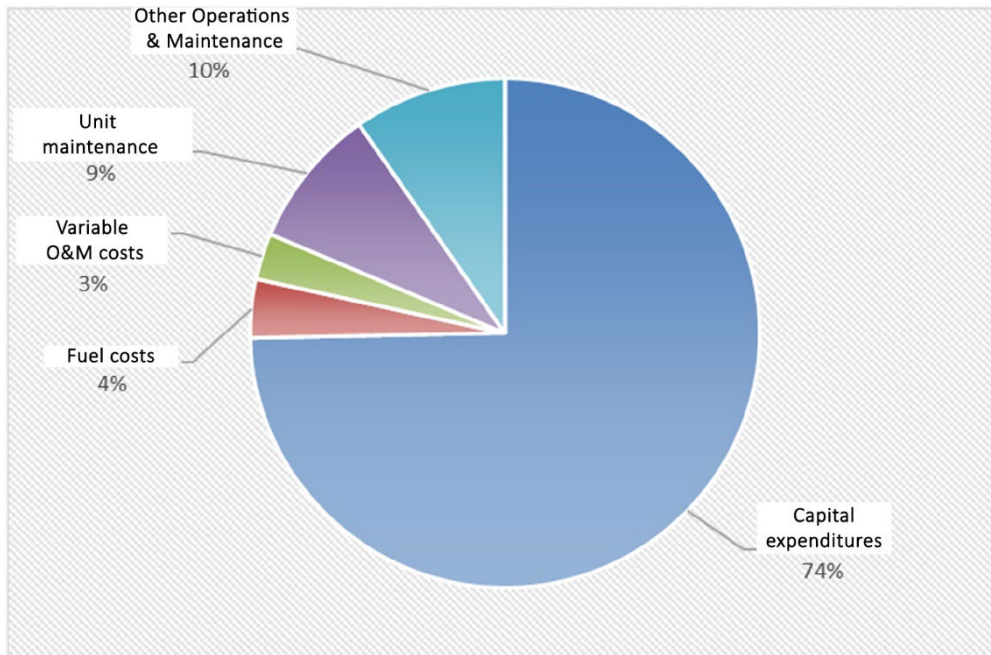

Figure 42 Structure of the calculated LCoE for the AP-1000 unit (Brownfield)

7.5. Sensitivity analysis

A sensitivity analysis was performed for the Brownfield option, analysing the following key variables within a range of +/- 50% (the first two items) or within a range of possible values (the last two items):

- capital expenditure,
- nuclear fuel price,
- unit gross capacity factor (GCF).
- weighted average cost of capital (WACC)

It was assumed that only one variable is subject to change at a given moment. The other variables remained at the same base level.

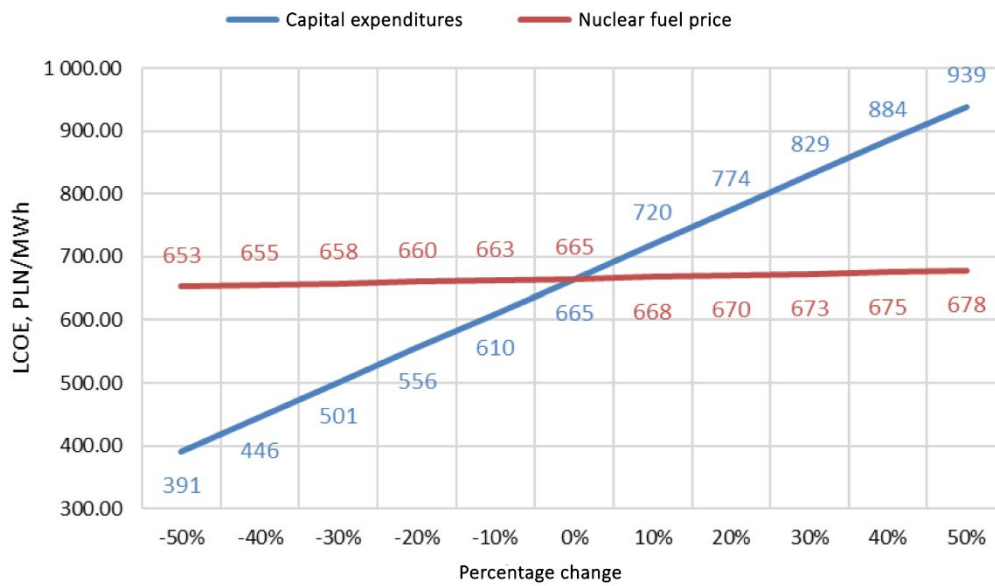

Figure 43 Sensitivity analysis results – capital expenditure and nuclear fuel price

Capital expenditure has a greater impact on LCOE, while changes in fuel costs have a negligible impact on the cost of electricity generation.

The sensitivity analysis for **changes in output** was conducted based on a change in the assumed gross capacity factor (GCF) ranging from 20% to 93%. A GCF of 100% would most likely not be achievable, which is why the maximum value of the capacity factor is 93% – the figure given by the IAEA⁴⁵ as the typical availability of an AP-1000 unit.

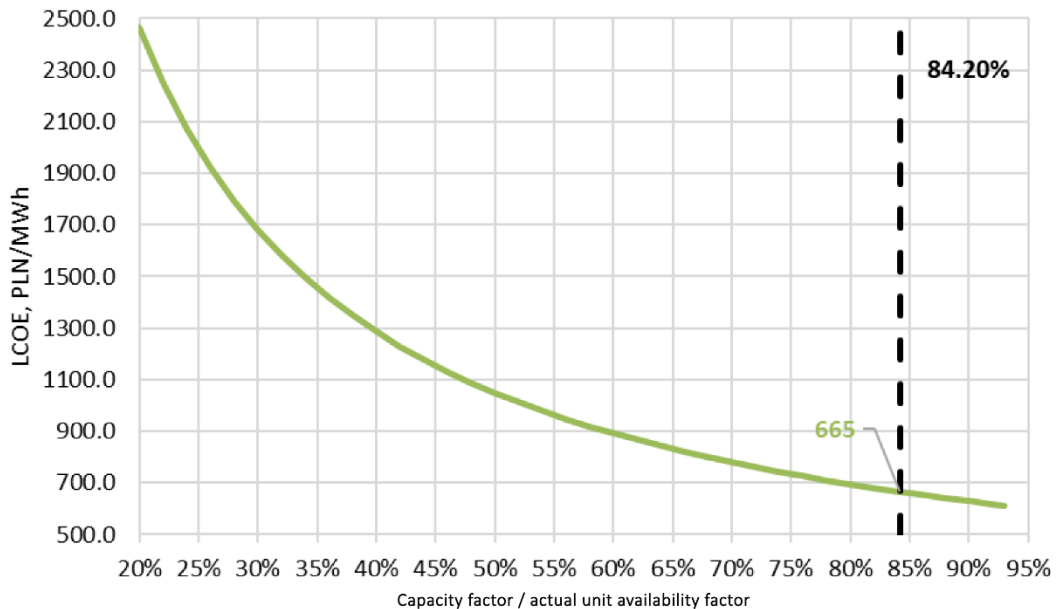

Figure 44 Sensitivity analysis results – unit availability

⁴⁵ IAEA, Status report 81 – Advanced Passive PWR (AP 1000)

The graph shows how heavily the LCoE indicator is dependent on generation; in the case of very low availability, the production cost rises to over PLN 2,000/MWh.

In addition, a sensitivity analysis was carried out on **the WACC discount rate**, ranging from 4%–10%. The graph shows the assumed WACC rate of 6.98%.

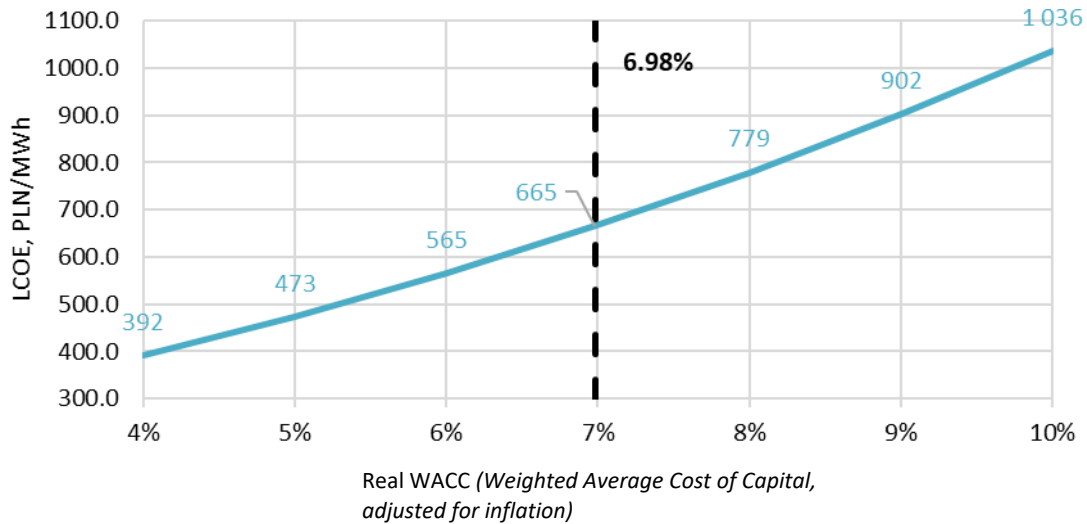

Figure 45 Sensitivity analysis results - variable discount rate

A change in WACC has a significant impact on LCoE, but changing it is not, in reality, a simple matter, and depends on a number of macro- and microeconomic factors in the country.

7.6. Summary of the economic analysis

- Based on the assumptions adopted in the modelling, the LCoE for AP-1000 technology in Kozenice is estimated at approximately PLN 665-672/MWh (Brownfield vs Greenfield).
- The use of existing infrastructure in the investment process (Brownfield) allows for an LCoE that is approximately PLN 7/MWh lower.
- The LCoE structure shows that capital costs are the main cost component – approx. 74%.
- A sensitivity analysis shows that the project is most sensitive to changes in capital expenditure. The discount rate (WACC) is also a significant parameter. The price of nuclear fuel has a negligible impact on profitability indicators.
- It is crucial to ensure adequate unit productivity in the market, as a decrease in the unit's availability leads to a drastic increase in electricity generation costs.
- At the specified LCoE level, the implementation of this type of investment must be based on guaranteeing revenues at an appropriate level, e.g., through a contract for difference, which will ensure a return on the investment expenditure incurred.

8. Analysis of required competencies for the management and operation of a nuclear power plant with characteristics specific to the investment option (based on the database of required competencies resulting from Research Task No. 6)

The energy transition from coal-to-nuclear technology (C2N) requires a restructuring of the technical and engineering workforce. Generating added value to the economy and society in this process may also involve utilising the skills of coal-fired power plant employees in nuclear power plants.

A rationally conducted power plant transformation process can have positive effects such as:

- no need to lay off a large proportion of employees;
- no need to recruit a large number of new employees;
- no need for some of the staff to relocate.

Significant negative effects and risks associated with the C2N transition for coal-fired power plant employees include:

- unemployment during the transition period;
- the need for further training;
- the need to acquire new qualifications.

The transformation of a coal-fired power plant into a nuclear power plant also results in a lack of demand for certain specialisations and the need to employ people with new specialisations.

A rational design of the C2N transition may therefore also take into account the course of action regarding the use of technical and engineering staff at coal-fired power plants.

The procedure for expanding or acquiring the competences required by engineering and technical staff can be started by determining the structure of the staff in existing and planned power plants and power units. The employment structure in a power plant or nuclear power unit determines the target human resources and their competences. The literature in this field presents lists of employee occupations together with the percentage share of a given type of position⁴⁶. This data, together with the total number of employees, allow the target employment structure in individual occupations to be determined. Similarly, for coal-fired power plants, a list of occupations and their percentage share is available. A direct comparison of this data for a given location allows for an assessment of the possibilities for direct transition, often requiring only a slight expansion of qualifications.

In order to prepare procedures for expanding or acquiring the competences required by the engineering and technical staff of modernised power plants and power units, sample case studies were presented, the essence of which was to determine the positions and number of jobs that require staff with completely new qualifications or that require further training. Similarly, the positions and number of jobs were identified for coal-fired power plant personnel who would not be able to find employment in the new power plant or nuclear unit due to the need for complete retraining.

Based on these analyses, it is possible to examine in greater detail the competencies required for the most important positions at a nuclear power plant, along with identifying opportunities for further training or retraining.

In this regard, it is also possible to indicate proposed pathways for further training or retraining.

46 Hansen J., Jenson W., Wrobel A., Stauff N., Biegel K., Kim T., Belles R., Omitaomu F.: Investigating Benefits and Challenges of Converting Retiring Coal Plants into Nuclear Plants. Systems Analysis and Integration; Revision 2 Prepared for U.S. Department of Energy 13 September 2022 ;INL/RPT-22-67964

8.1. The most important elements of procedures for expanding or acquiring the competences required by the engineering and technical staff of modernised power plants and power units

The use of the competences of the engineering and technical staff of a power plant or coal-fired unit in a nuclear power plant or unit can bring many economic and social benefits. These effects can be achieved by rationally defining possible procedures for expanding or acquiring the competences required in new power plants.

The most important issues to consider when designing the process are:

- determining the positions necessary in the new power plant or unit;
- determining the number of positions for each job in the new power plant or unit;
- determining the positions in the power plant or unit being decommissioned;
- determining the number of positions in the decommissioned power plant or unit;
- determining the timetable for the creation of positions and full-time positions in the new unit or power plant;
- determining the timetable for the liquidation of positions and full-time positions in the power plant or coal-fired power unit.

With the information provided, it is possible to determine the matrix of positions and jobs in the plant being liquidated and the one being established. Such a matrix makes it possible to determine the positions and jobs in which:

- there is little or no need to expand employees' competences;
- it is possible to retrain or acquire new competences in a relatively short period of time;
- for which complete retraining is necessary.

The timetables for the decommissioning and commissioning of power plants or power units allow the process to be supplemented with information on possible career paths and opportunities for employees to upgrade their skills, e.g., during the construction of a new power plant or unit.

8.2. List of jobs with the highest employment in a nuclear power plant

The list of job roles with the highest number of employees helps to determine the demand for the most important job roles. The analyses first identified the number of posts for ten jobs (those with the highest number of employees) for a nuclear power plant with an electrical capacity of 1GW (Table 21). The data was compiled on the basis of [9]. This source indicates that employment in a modern nuclear power plant built on the basis of 10 SMR units amounts to 341 full-time jobs (directly employed). This data was compared with the number of full-time positions that will be eliminated at a coal-fired power plant also with a capacity of 1 GW. In this case, it was assumed that the total number of direct full-time positions is 145.

Table 27 List of the most common jobs in a nuclear power plant

Coal-fired power plant			Job title	Nuclear power plant		
Percentage of employees	Number of jobs 1GW	Percentage of jobs increasing		Percentage of employees	Number of full-time positions in 1GW	Percentage of positions increasing by
0.31	-0.45	0.31	Nuclear engineers	13.07	44.64	13.07
0.31	-0.45	0.62	Nuclear reactor operators nuclear	10.96	37.44	24.03
0.52	-0.75	1.14	Security guards security	10.96	37.44	34.98
0.62	-0.9	1.75	Nuclear technicians	7.17	24.48	42.15
4.33	-6.3	6.09	First-line managers of production and operational staff	5.06	17.28	47.21
5.37	-7.8	11.46	Electrical and electronic equipment repairers, power stations, substations and relays	3.06	10.44	50.26
0.52	-0.75	11.97	Training and development specialists development	2.85	9.72	53.11
4.64	-6.75	16.62	Electrical engineers	2.85	9.72	55.95
0.83	-1.2	17.44	Managers for Architecture and Engineering	2.74	9.36	58.69
3.20	-4.6	20.64	Industrial machine mechanics Industrial	2.74	9.36	61.43

An analysis of the data shows that the ten jobs listed account for as much as 61% of the jobs at a nuclear power plant. The same jobs account for approximately 21% of the jobs at a coal-fired power plant. These jobs include: Nuclear engineers; Nuclear reactor operators; Security guards; Nuclear technicians; Training and development specialists; Architecture and engineering managers - whose share in a coal-fired power plant is less than one per cent. It can be assumed that these positions must be filled almost entirely by people from outside the nuclear power plant or by people from the coal-fired power plant who have undergone comprehensive training.

Due to the greater number of jobs in total at a nuclear power plant, some positions at coal-fired power plants may be transferred in their entirety to nuclear power plants. The positions in question include First-line managers of production and operational staff; repairers of electrical and electronic equipment, power plants, substations and relays; electrical engineers; industrial machine mechanics.

8.3. List of jobs with the highest employment in a coal-fired power plant

A list of the most common positions at a coal-fired power plant is also helpful in determining procedures for the use of engineering and technical staff. As in the previous section, a comparison with the requirements of a nuclear power plant allows us to identify groups of positions that will not find employment at a nuclear power plant or require complete or partial retraining.

The analyses identified fourteen jobs with the highest number of positions (Table 22). Data from studies based on ⁴⁷

Table 28 List of the most common jobs in a coal-fired power plant

Coal-fired power plant			Job title	Nuclear power plant		
Percentage of employees	Number of jobs 1GW	Percentage of full-time positions cumulative		Percentage of employees	Number of full-time positions 1GW	Percentage cumulatively
17.44	25.4	17.44	Power plant operators	0.63	2.2	0.63
7.02	10.2	24.46	Installers and repairers of power lines	0.74	2.5	1.37
5.37	7.8	29.82	Electrical and electronic equipment repairers, power stations, substations and relays	3.06	10.4	4.43
4.64	6.8	34.47	Electrical engineers	2.85	9.7	7.27
4.33	6.3	38.80	First-line managers of production and operational staff	5.06	17.3	12.33
3.61	5.3	42.41	Customer service representatives customer	0	0	12.33
3.20	4.7	45.61	Industrial machine mechanics Industrial	2.74	9.4	15.07
3.10	4.5	48.71	First-line managers mechanics, installers	2.53	8.6	17.60
2.37	3.4	51.08	Installers and repairers of control systems and valves, except for mechanical doors mechanical	0.21	0.7	17.81
2.06	3	53.15	Electricians	1.69	5.8	19.49
2.06	3	55.21	Distributors and electricity dispatchers	0.32	1.1	19.81
1.86	2.7	57.07	Chief executives and operational managers	0.74	2.5	20.55
1.75	2.55	58.82	Project management specialists and business operations specialists, all others	2.11	7.2	22.66
1.44	2.1	60.27	Management analysts	0.63	2.2	23.29

In the case of coal-fired power plants, 14 positions account for 60% of full-time jobs. These roles account for approximately 23% of employees at nuclear power plants.

⁴⁷ Hansen J., Jenson W., Wrobel A., Stauff N., Biegel K., Kim T., Belles R., Omitaomu F.: *Investigating Benefits and Challenges of Converting Retiring Coal Plants into Nuclear Plants. Systems Analysis and Integration; Revision 2 Prepared for U.S. Department of Energy 13 September 2022 ;INL/RPT-22-67964*

Within this group of occupations, although some account for only a small percentage of posts at a nuclear power station, due to the significant disparities between the workforce at nuclear and coal-fired power stations, only some of these roles will not be filled at a nuclear power station. This applies in particular to Power plant operators; Power line installers and repairers; Customer service representatives; Installers and repairers of control systems and valves (except for mechanical doors); Electricity distributors and dispatchers

8.4. List of jobs with the greatest shortage at nuclear power plants and the greatest surplus at coal-fired power plants

By comparing the number of jobs for individual positions at coal-fired and nuclear power plants, it is possible to identify shortages and surpluses. A list of the jobs with the largest surplus at coal-fired power plants and the largest shortage at nuclear power plants allows for an assessment of the possibility of retraining some employees to work at the new power plant. A list of the most important positions, together with the number of jobs for a 1GW nuclear and coal-fired power plant, is presented in Table 29.

Table 29 Summary of the most important positions with shortages and surpluses of jobs in coal-fired and nuclear power plants

Nuclear power plant	Shortage	Surplus	Coal-fired power plant
Nuclear engineers	44.19	23.19	Power plant operators
Nuclear reactor operators	36.99	7.68	Power line installers and repairers
Security guards	36.69	5.25	Customer service representatives
Nuclear technicians	23.58	2.73	Installers and repairers of control systems and valves (except mechanical doors)
First-line managers of production and operational staff	10.98	1.92	Electricity distributors and dispatchers
Training and development specialists	8.97	1.8	Operations engineers and other staff
Architectural and engineering managers engineering	8.16	1.05	Plant and system operators water and sewage treatment
Industrial machinery mechanics Industrial	4.71	0.9	Stationary engineers and boiler operators
Project management specialists and business operations specialists, all other	4.65	0.78	Welders, cutters, solderers and brazers
Various first-line managers, security personnel	4.53	0.75	Gas plant operators
First-line managers of mechanics, installers and repairers	4.14	0.6	Accounting, auditing and auditing staff
Industrial engineers	4.02	0.6	Bus and lorry mechanics and diesel engine specialists Diesel engine specialists
Health and safety specialists	3.57	0.6	Calibration technologists and technicians and engineering technologists and technicians, engineering, except draughtsmen, all others

Personal services managers, all others; entertainment and recreation managers, except gambling and managers, all others	3.42	0.6	Construction managers
Electrical engineers	2.97	0.6	Truck and tractor operators Industrial
Office clerks, general	2.91	0.6	meter readers, utilities
Electricians	2.76	0.6	Mobile heavy equipment mechanics equipment, except engines
Production managers	2.76	0.6	Hydraulic engineers, pipeline fitters and steam fitters
Production, planning and dispatch clerks	2.76	0.45	dispatchers, except police, fire brigade and ambulance services Emergency services
Repairers of electrical and electronic equipment, power plants, substations and relays	2.64	0.45	Electrical and electronic draftsmen
Training and development managers	2.37	0.45	Assistants — installation, maintenance and repair workers Installation, maintenance and repair
Chemists	2.07	0.45	lawyers
Chemical technicians	1.92	0.45	Maintenance workers, machinery
Mechanical engineers	1.86	0.45	Plant and systems operators,
Service managers and facilities	1.83		
Executive secretaries and administrative assistants	1.62		
Engineers, all others	1.56		
Technical writers	1.44		
Compliance specialists	1.41		
Security analysts information	1.35		
Industry engineers, technicians and technicians	1.29		
Inspectors, testers, sorters, samplers and weighers	1.14		
Chemical engineers	1.08		
Crisis management directors	1.08		
Environmental and safety technicians protection technicians, including health services	1.08		

Based on the data provided, it can be seen that the largest group of positions in a coal-fired power plant for which there is no equivalent in a nuclear power plant are power plant operators (control, operation and maintenance of machinery and equipment for electricity generation and auxiliary systems).

People in these positions have specialist technical knowledge and skills related to machinery, equipment and installations that are not found in such quantities, or at all, in nuclear power plants. Due to their technical education and the relatively large number of positions available, they may consider undertaking supplementary studies which, after completing an internship, would enable them to work in technical and engineering positions related to reactor operation. This retraining path is quite long and may involve a temporary reduction in salary (during the period of re-education and internships), so it may be more suitable for younger people. Often, during the transition from a coal-fired to a nuclear power plant, there may be a longer period during which the coal-fired power plant is no longer in operation and the nuclear power plant is not yet commissioned. On the one hand, this gives time to retrain some of the employees, but on the other hand, it may be unacceptable due to the temporary lack of livelihood (taking up employment during the training period may be burdensome).

The analyses also highlight another group of people working as power line installers, where there is a surplus of jobs in relation to coal-fired power plants. These positions are often filled by people with electrical training who can obtain jobs as electricians, electrical and electronic equipment repairers, or electrical engineers, where there may be shortages.

8.5. Summary of information on selected jobs in a nuclear power plant

The literature contains a range of information on jobs in nuclear power plants and the nuclear sector.

⁴⁸ presents a summary of literature with characteristics in which classifications of occupations related to the nuclear sector can be found. It lists several studies, mainly from countries where the nuclear sector is of significant importance. These summaries differ significantly in terms of the names of positions and their characteristics, which may be due to the fact that different countries often draw on their own experience in this field.

⁴⁹ contains a list of positions related to the nuclear sector, including the operation of nuclear power plants. Selected positions are described in terms of initial qualifications, competences (divided into the scope of knowledge and responsibility), additional training and development. Within the indicated areas, additional distinctions are made between technical, operational, business and personnel issues.

Based on ⁵⁰, it can be concluded that the positions that are significant in terms of the number of jobs and the need for training are: nuclear engineer and nuclear reactor operator. These positions are described in more detail in the following subsections.

8.6. Nuclear engineer

According to the Standard Occupational Classification (SOC)⁵¹ which was the basis for the analysis of the matrix of positions and posts, this position involves conducting research on nuclear engineering projects or applying the principles and theories of nuclear science to problems related to the release, control and use of nuclear energy and the storage of nuclear waste.

⁴⁸ ERIKSSON, A. and ERIKSEN, B. Job Classification and Taxonomy in the Nuclear Sector, European Commission, Petten, JRC132572

⁴⁹ C. Cheneil Ramas, *Nuclear Job Taxonomy. Final Report*, EUR 29126 EN, Publications Office of the European Union, Luxembourg, 2018, ISBN 978-92-79-73842-5, doi 10.2760/090414, JRC110868

⁵⁰ Hansen J., Jenson W., Wrabel A., Stauff N., Biegel K., Kim T., Belles R., Omिताomu F.: *Investigating Benefits and Challenges of Converting Retiring Coal Plants into Nuclear Plants. Systems Analysis and Integration; Revision 2 Prepared for U.S. Department of Energy 13 September 2022 ;INL/RPT-22-67964*

⁵¹ *Standard Occupational Classification Manual Executive Office of the President; Office of Management and Budget; United States, 2018*

Based on ⁽⁵²⁾ this position can be described in terms of functions, knowledge and skills.

Functions:

- Responsible for core calculations in strict compliance with nuclear safety regulations during all operations with new and spent nuclear fuel.
- Calculation of the nuclear reactor core and spent fuel pool.
- Determining reactor operating limits based on authorised or licensed fuel operating limits. Compliance with fuel specifications for new fuel. Receipt and inspection of new fuel. Monitoring and collecting data on the condition of the reactor core during operation.
- Performing calculations to ensure safety (core/reactor cooling system conditions within licensed limits) and performance (neutron flux distribution, core burn rate).
- Ensuring compliance of reactor core operating manoeuvres.
- Fuel load design (fuel movements, location of the fuel assembly in the reactor core/spent fuel pool).
- Modelling and predicting reactor core behaviour under changing operating conditions.
- Supervision of nuclear fuel-related activities during refuelling operations.
- Development of working documents (procedures, programmes, instructions) for reactor start-up.
- Preparation and evaluation of reactor core tests prior to start-up.
- Collecting data and monitoring radiation damage to the core and reactor pressure vessel structures.
- Monitoring, data collection and control of nuclear materials (i.e. fuel assemblies, core monitoring instruments) and other core-related equipment: sources, fuel connections, control rods

Job requirements Knowledge (Cognitive competences) EQF level (1-8)

Reactor physics theory 7 Nuclear safety principles and requirements 6 Safety culture 6 Engineering graphics, drawings and diagrams 6 Radiation protection 6 Nuclear physics 6 Nuclear safety regulations 6 Nuclear engineering 6 Nuclear apparatus in and outside the core (fission chambers, neutron flux monitoring) 6 Numerical methods of reactor design 6 Thermal-hydraulic design and analysis 6 Nuclear fuel (thermal limitations, operational limitations, etc.) 6 Core tests prior to start-up 6 Reactor core operation, limitations and set points 6 Nuclear power plant: reactor fundamentals, reactor and power plant process systems, auxiliary process systems, ionising radiation, heat generation and removal systems, steam supply system, nuclear chemistry, Measurement and control systems, electrical systems 5 National and international codes and standards 5 Industrial safety 5 Operational experience 5 Basic measuring instruments and procedures 5 Visual inspection 5 Materials science and radiation damage 5 Occupational safety and personal protective equipment 4 Quality assurance and control 4 Project management, planning methods and tools 4 Knowledge of information and communication technologies 4 Technical writing 4 Nuclear security 4

52 C. Cheneil Ramos, Nuclear Job Taxonomy. Final Report, EUR 29126 EN, Publications Office of the European Union, Luxembourg, 2018, ISBN 978-92-79-73842-5, doi

10.2760/090414, JRC110868

Skills (technical and functional competences) EQF level (1-8)

Using and interpreting engineering data and technical documentation. 7 Planning, coordinating, implementing and monitoring project activities. 6 Ensuring the compliance with engineering codes and standards. 6 Identifying possible interactions with other related disciplines. 6 Conducting reactor core analysis and designing fuel configuration. 6 Mapping the location of fuel assemblies in the core and spent fuel pool. 6 Calculating the neutron distribution flux map. 6 Calculating criticality and neutronics. 6 Collect data and monitor core operating conditions. 6 Determine reactor operating limits. 6 Monitor nuclear fuel safety operating parameters. 6 Monitor reactor core performance. 6 Predict/model/analyse reactor core behaviour. 6 Design reactor core operating manoeuvres. 6 Develop core operational manoeuvre procedures. 6 Receive and inspect new fuel. 6 Develop/verify new fuel acceptance and inspection procedures. 6 Collaborate on the development of technical specifications for new fuels. 6 Interpret core monitoring instrument readings. 6 Use and update databases of reactor fuel assemblies, connections, control rods, sources, etc. 6 Design reactor core test procedures, analyse and monitor results. 6 Ensure compliance with statutory regulations and QSE organisational requirements. 5 Draft and communicate requirements specifications, technical specifications, procedures and reports. 5 Identify safety requirements. 5 Retrieve technical information using computer-aided techniques. 4 Monitor and maintain a safe working environment. 4 Conduct work analysis, break down activities and assign tasks. 4 Evaluate performance and identify measures and indicators to improve or correct performance. 4 Maintain nuclear materials.

8.7. Nuclear reactor operators

According to the Standard Occupational Classification (SOC)⁽⁵³⁾ the main tasks in this position are operating or controlling nuclear reactors; moving control rods; starting and stopping equipment, monitoring and adjusting controls, and recording data in logs; implementing emergency procedures when necessary; the ability to respond to irregularities, determine causes and recommend corrective actions. This role is also described as: Nuclear Control Room Operator, Nuclear Reactor Operator, Nuclear Power Plant Operator.

This position can be described in terms of functions, knowledge and skills.

Functions:

- Responsible for all aspects of the safe operation of the reactor facility
- Ensures and monitors the safe and trouble-free operation of the reactor facility in accordance with the requirements of technical specifications: (radiation conditions, chemical regime, technological limitations and conditions)
- Provides overall supervision of all activities related to the operation of the reactor facility and its auxiliary systems, and directly manipulates the controls of the equipment and systems

⁵³ Standard Occupational Classification Manual Executive Office of the President; Office of Management and Budget; United States, 2018

- Monitors and controls the core, reactivity, and systems that may affect reactivity
- Ensures and controls strict compliance with nuclear safety and radiation protection requirements in all activities related to the operation of the reactor facility
- Reports to the unit shift manager on the operational status of the reactor facility and/or any incidents that have occurred
- Coordinates maintenance and testing activities and equipment start-up after maintenance
- Monitors the parameters of assigned equipment during operations and ensures response to system or unit anomalies, diagnoses the cause, recommends or applies corrective actions, and reports incidents
- Responsible for recording and continuously updating operational logs
- During a fuel supply interruption, coordinates and monitors activities in the controlled area
- In the event of an abnormality or emergency, strictly follows the instructions of the Unit Shift Manager in accordance with Emergency Operating Procedures and the internal emergency plan
- Collaborate with other departments within the organisation as part of their duties
- Responsible for implementing operational procedures, such as controlling start-up and shutdown activities, including periodic testing of relevant equipment

Job requirements Knowledge (Cognitive skills) EQF level (1-8) Nuclear engineering: reactor physics, thermal limitations of nuclear fuels, nuclear power plant systems, heat transfer in reactors and fluid flow 6 Occupational safety and personal protective equipment 6 Operational experience 6 Nuclear power plant operation: operation of reactor systems: reactor start-up, normal, transient and emergency operation, measurement of operating parameters, power plant dynamics and control, reactor core operation, instruments and applications 6 Nuclear safety 6 Physics and chemistry theory: thermodynamics, fluid mechanics 5 Applied techniques and engineering: electricity generation, energy conversion, mechanics, electrical engineering, operation of the power system, electrical engineering, energy conversion, sensors, measurements, signal processing, instrumentation and control, pipeline systems, pumps and turbines, hydraulic and pneumatic installations 5 Technical drawings and diagrams 5 Nuclear safety culture 5 Emergency preparedness 5 Nuclear energy science Understanding complex regulations and procedures 5 Industrial chemistry 4 National and international regulations, codes and procedures related to safe operation 4 Radiation protection 4 Human error prevention techniques 4 Corporate procedures 4 Accident analysis and accident modelling 4 Risk assessment 3 Materials science 3.

Skills (technical and functional competences) EQF level (1-8)

Maintaining energy equipment in safe and economical operating conditions in accordance with technical specifications and procedures. 6 Recognising and reporting abnormal situations in the power plant. 6 Monitoring the condition of technical equipment and systems. 6 Anticipating the results of actions in systems and components and carrying out any necessary corrective actions. 6 Identifying measures or indicators of system performance and predicting how changes in conditions or actions will affect outcomes. 6 Communicating instructions using safe and effective communication techniques. 6 Carrying out operational and emergency plans and procedures. 6 Operating and monitoring computer-controlled equipment. 6 Adjusting operating parameters using information from recorders and displays. 6 Reading and interpreting technical drawings and diagrams. 5 Preparing technical reports and operational records. 5 Verifying the condition of equipment using measuring and testing instruments. 5 Correcting abnormal conditions in accordance with standard practice and instructions received. 5 Maintaining and updating repair logs, tracking and reporting systems. 4 Providing data for the preparation of nuclear safety documentation. 4 Monitor and maintain a safe working environment. 4 Perform visual inspections. 4 Comply with statutory regulations and organisational safety requirements. 4 Contribute to the design of requirements specifications. 4 Operate computers using specified software. 4

Based on ⁽⁵⁴⁾ this position can be described as follows:

Entry qualifications: Degree in engineering or a related scientific field and/or rigorous training programmes related to nuclear energy and significant experience.

Job description

The reactor operator is responsible for manipulating the power plant controls, monitoring its operation, directing the direct operation of equipment, and performing licensed activities during start-up, shutdown, power changes, emergency and accident situations, as well as in special conditions. Reactor operators primarily operate the power plant controls from the control room.

Competencies (Technical (T), Regulatory (R), Business (B), Personal (P))

A reactor operator should be able to:

- Manipulate power plant controls in accordance with plant procedures. (T, R)
- Apply theoretical knowledge in practical situations. (T)
- Analyse the operation of power plant equipment and take corrective action for normal and abnormal conditions in accordance with plant procedures and available information. (T, R)
- Use plant procedures and technical specifications to implement appropriate actions under normal, unusual and emergency conditions. (T, R)
- Maintain the power plant in a safe condition in the event of uncertain or unexpected conditions. (T, R)
- Effectively control and coordinate the activities of subordinates and other individuals. (R, B)

⁵⁴ Standard Occupational Classification Manual Executive Office of the President; Office of Management and Budget; United States, 2018

- Act as an effective member of the shift team in the control room. (B, R)
- Perform duties in support of the emergency plan. (R, P)
- Take a conservative approach to plant operations. (R, P)
- Collaborate with other groups to solve problems. (P, B)

The reactor operator should understand:

- Concepts, philosophy and responsibilities of the unit operator in the field of reactivity management and reactor core safety. (T, R)
- Advanced technical fundamentals, plant design, theory and interdependencies of systems for which operators are responsible. (T)
- Relationships between different departments within the plant – quality assurance, engineering, maintenance, training, radiation protection. (T, B)
- Administrative procedures and regulatory requirements for plant management. (T, R)
- Concepts of probabilistic safety assessment and the importance of key components in mitigating the consequences of accidents. (T, R)
- Procedures, programmes, company policies, industry guidelines and best practices. (T, R)
- Error prevention techniques and human performance tools. (T, B)
- How to conduct pre- and post-operation briefings. (T, B)
- How to make conservative decisions, with the highest priority given to protecting the health and safety of personnel and the public. (P, T)

Recommended training/CPD: (Technical (T), Regulatory (R), Business (B), Personal (P)):

- Advanced technical fundamentals, e.g., plant systems description and reactor operator theory. (T)
- Radiation protection. (T)
- Reactor thermohydraulics. (T)
- Operating licences and technical specifications. (T, R)
- Simulator training: integrated normal plant operations, diagnostics, emergency procedures, responses to accidents and transient operating conditions. (T, R)
- Probabilistic safety assessment. (T, R)
- Safety analysis reporting. (R)
- Advanced analysis of transients and accidents, (T, R)
- Mitigation of core damage effects. (T, R)
- Error prevention techniques and human performance tools. (T, B)
- Teamwork. (P)
- Conservative decision-making. (T, B)
- Nuclear safety and safety culture. (T, R)
- Operational experience and emergency planning. (T, R)
- Work-related policies and procedures. (T, R, B)

9. Risk analysis regarding the organisation and safety of modernisation and operation of power units with nuclear reactors (based on the results of Research Task No. 3, which sets out key requirements and recommendations concerning nuclear safety for selected sites)

9.1. Legal requirements

9.1.1. General requirements for the location of a nuclear power plant

Polish law sets out general requirements for the location of nuclear power plants, aimed at ensuring the safety of both the population and the environment. The key requirements, contained in the Act of 29 November 2000 – Atomic Law, concern the assessment, planning and selection of suitable locations for nuclear power plants.

9.1.1.1. Radiological safety and health protection of the population

A nuclear power plant must be located in such a way as to ensure maximum safety for the population against the effects of potential accidents, including the release of radioactive materials. The choice of location should take into account the reduction of the risk of radiation exposure to the population and compliance with the requirements for radiological protection specified in national and international regulations.

9.1.1.2. Seismic and geological risk analysis

Atomic law requires that the location of a nuclear power plant take into account all possible geological hazards, such as earthquakes, landslides, flooding or terrain deformation, which could affect the stability and safety of the nuclear facility. A detailed geological and seismic assessment is necessary to minimise the risk associated with the impact of natural forces on the operation and safety of the facility.

9.1.1.3. Environmental protection

The location of a nuclear power plant must meet environmental protection requirements, which means that a comprehensive environmental impact assessment (EIA) must be carried out. This assessment analyses the potential impact of the investment on the air, water, soil, fauna and flora. The EIA process must also take into account the impact on water resources that may be used to cool the reactors, as well as on the local climate and ecosystems.

9.1.1.4. Compliance with spatial development plans

A nuclear power plant must be located in accordance with local spatial development plans. The planning process requires cooperation with local authorities and relevant public administration bodies to ensure that the investment is compatible with local conditions. The impact on transport infrastructure, transport accessibility and possible evacuation needs must also be taken into account.

9.1.1.5. Distance from population centres and critical infrastructure

The location of a nuclear power plant should be sufficiently distant from large population centres and key critical infrastructure. Limiting the impact of potential accidents on the surrounding area is a priority, which is why the location must meet specific standards and regulations regarding the minimum distance from residential areas and strategic facilities.

9.1.1.6. Availability of technical infrastructure

The requirements also apply to the availability of appropriate technical infrastructure necessary for the operation of the power plant, including power connections, access to water sources for reactor cooling, transport infrastructure (road and rail), and emergency and communication infrastructure.

9.1.1.7. Ensuring an adequate level of physical protection

The location of the power plant must allow for adequate physical protection of the facility against external threats, including acts of sabotage, terrorism and air attacks. Regulations impose an obligation to use modern protection and security systems that minimise the risk associated with external factors.

9.1.1.8. Cooperation with the local community and public consultations

Public consultations and information campaigns are required in order to present the impact of the power plant location on the surrounding area and to gather the opinions of residents and interested parties. Such activities are aimed at increasing the transparency of the location process and building public acceptance for the project.

9.1.1.9. Compliance with international regulations and IAEA regulations

As a member of the International Atomic Energy Agency (IAEA), Poland must comply with international standards and guidelines on the location and safety of nuclear facilities. In this context, best practices in risk assessment, emergency management and environmental protection are taken into account.

In summary, the selection of a location for a nuclear power plant in Poland is subject to detailed analysis in accordance with the requirements of the Atomic Energy Act, aimed at ensuring maximum safety, minimising environmental impact and guaranteeing an adequate level of public health and safety.

9.1.2. General requirements for the design of nuclear reactors and nuclear power plants

The Regulation of the Council of Ministers of 31 August 2012 on nuclear safety and radiation protection requirements (Journal of Laws 2012, item 1048 - *Dz.U. 2012, poz. 1048*) specifies detailed requirements for the design, construction and operation of nuclear facilities, including nuclear reactors, in Poland. The purpose of these requirements is to ensure the maximum level of nuclear safety and radiological protection for the public, personnel and the environment.

9.1.2.1. Basic principles of nuclear safety

- **Defence in depth:** The design of the reactor and the entire power plant must be developed in accordance with the principle of 'defence in depth', which means the use of multiple physical and organisational barriers to prevent the release of radioactive substances. This requires the existence of systems to prevent, detect and mitigate the effects of possible accidents.
- **Protection against accidents:** The design must minimise the risk of accidents and ensure that the possible consequences of accidents are controlled and limited in order to prevent serious consequences for the population and the environment.

9.1.2.2. Safety system design

- **System reliability:** All safety systems, including reactor cooling systems, must be highly reliable. Redundancy (duplication of key components) and technical diversity are required to prevent failures resulting from a single point of failure.
- **Passive and active systems:** Safety systems must be capable of operating both passively (without the need for electrical power) and actively in order to ensure the highest possible level of safety.
- **Ability to shut down safely:** The design must take into account the possibility of safely and immediately shutting down the reactor in an emergency situation and ensuring long-term heat removal after shutdown.

9.1.2.3. Protection against external and internal hazards

- **Resistance to external factors:** The nuclear facility must be designed to withstand various external factors, such as earthquakes, floods, extreme weather conditions, fires and aircraft crashes.
- **Internal hazards:** The design must take into account protection against internal hazards such as system failures, internal fires, explosions and possible human error.

9.1.2.4. Radiological protection

- **Minimisation of radiation exposure:** The design must ensure that radiation exposure to staff and the public is minimised through the use of physical barriers, appropriate radiation protection and monitoring systems.
- **Ventilation systems:** Ventilation systems must be designed with the capability of filtering air contamination and controlled release of radioactive substances into the atmosphere, in accordance with applicable standards.

9.1.2.5. Facility monitoring and control

- **Monitoring systems:** The power plant design must include advanced systems for monitoring and controlling reactor operating parameters, including systems for detecting failures and safety breaches.
- **Automated control systems:** It is recommended to use automated control systems that allow for rapid detection of irregularities and the implementation of appropriate corrective or preventive measures.

9.1.2.6. Physical security and facility protection

- Physical protection: The facility design must provide an adequate level of protection against unauthorised access, sabotage or external attacks.
- Integrated security systems: This includes monitoring, alarm systems and access control to prevent deliberate actions that could threaten the security of the facility.

9.1.2.7. Procedures for accidents and emergencies

- Emergency response plans: The power plant design must include detailed plans for responding to both internal and external emergencies and provide for the possibility of rescue operations involving external services.
- Evacuation and personnel safety systems: Consideration of evacuation routes, personnel protection procedures and other elements ensuring minimisation of the effects of a potential accident.

9.1.2.8. Requirements for radioactive waste management

- Safe storage of waste: The design must include systems for the safe collection, storage and management of radioactive waste generated during the operation of the power plant.
- Waste minimisation: Efforts should be made to minimise the amount of radioactive waste and to store and process it appropriately in accordance with regulations.

9.1.2.9. Technical qualification of components and materials

- Compliance with norms and standards: All elements and components must be designed and manufactured in accordance with international norms and standards for nuclear safety.
- Certification and testing: Appropriate testing, certification and quality verification of the materials and equipment used is required.

The Regulation of 31 August 2012 (*Rozporządzenie z 31 sierpnia 2012 r.*) imposes a wide range of technical requirements on nuclear facility designs to ensure the highest level of safety, radiation protection and resistance to various hazards. Each design must be developed in a comprehensive manner, taking into account the specific technological characteristics, radiological safety, hazard protection and emergency management.

9.2. Kozienice power plant

9.2.1. General characteristics of the Kozienice facility

The Kozienice Power Plant is Poland's largest hard coal-fired power plant. It is located in Świerże Górne, in the municipality of Kozienice, in the Mazowieckie Province.

This power plant is an important component of the national electricity system. Below are the general technical characteristics of the facility:

Total installed capacity: 4,020 MWe

1972: B1 – 200 MW

1973: B2, B3, B4, B5 – 200 MW

1974: B6, B7 – 200 MW

1975: B8 – 200 MW

1978: B9 – 500 MW

1979: B10 – 500 MW

2017: B11 – 1,075 MW

9.2.2. General characteristics of the AP1000 reactor

The DEsire project envisages replacing the ten oldest power units at the Kozienice power plant with two nuclear units equipped with AP1000 reactors.

The AP1000 nuclear reactor is a modern, technologically advanced pressurised water reactor (PWR) designed by Westinghouse Electric Company. It is one of the latest Generation III+ reactors, characterised by enhanced safety levels, simplified design systems and greater efficiency.

9.2.2.1. Key technical parameters

- - Reactor type: Pressurised Water Reactor (PWR).
- - Thermal power of the reactor: Approximately 3,400 MWt.
- - Net electrical power: Approximately 1,117 MWe.
- - Power plant efficiency: Typically around 33% (depending on operating conditions).

9.2.2.2. Technological advantages

The AP1000 reactor utilises passive safety systems that operate without the need for external electrical power or operator intervention for at least 72 hours in the event of a failure. Passive cooling and emergency control systems utilise natural physical phenomena such as gravity, convection and pressure differentials, which significantly reduce the risk of failure resulting from loss of power. Compared to older reactors, the AP1000 features a simplified piping system design, fewer pumps, valves and mechanical components, which reduces construction and maintenance costs and increases reliability. The reactor's design allows for the prefabrication of large components off-site, which reduces construction time and costs.

9.2.2.3. Passive safety systems

Passive Core Cooling System (PCCS): In the event of a failure, the core cooling system uses a water tank located above the reactor and natural water flow to cool the core and prevent it from overheating.

Passive Containment Cooling System (PCS): Uses natural air convection and water cooling of the pressure vessel to dissipate heat in the event of a failure.

Passive post-shutdown heat removal system: Heat from the reactor can be removed without the use of pumps, which increases the reliability of the cooling system in emergency situations.

9.2.2.4. Reactor and fuel design

The AP1000 reactor uses fuel in the form of fuel rods made of uranium enriched to approximately 4-5% uranium-235 isotope, similar to most other PWR reactors. The reactor core consists of fuel assemblies that are arranged in a manner that ensures efficient fuel utilisation and optimisation of the nuclear reaction. The operating cycle with fuel replacement usually lasts 18-24 months, which ensures extended operating time without the need for downtime for refuelling.

9.2.2.5. Pressurised containment protection systems

The reactor has a double safety enclosure that protects against the release of radioactive substances in the event of a failure. The pressure vessel is made of highly durable materials (steel, concrete), which ensures resistance to high pressure and temperatures as well as external hazards (e.g. earthquakes or aircraft impacts).

9.2.2.6. Automation and control systems

The AP1000 reactor is equipped with state-of-the-art automatic control systems that enable real-time monitoring and control of reactor operation, thereby increasing safety and operational efficiency. Crucially, these systems minimise the risk of human error and ensure rapid response to changing conditions in the reactor.

9.2.2.7. Standards and certification

The AP1000 meets international safety standards and requirements set by the International Atomic Energy Agency (IAEA) and national regulatory agencies in many countries. Its design has been approved by the US Nuclear Regulatory Commission (NRC) and numerous regulatory authorities around the world.

9.2.2.8. Operation and reliability

Compared to older reactors, the AP1000 offers high reliability, longer service life and lower operating costs thanks to the use of modern technologies and a simplified design. The reactor is designed to operate for 60 years with the possibility of extending its service life.

In summary, the AP1000 reactor is a technologically advanced unit offering a high level of safety thanks to passive cooling and protection systems and a simplified design. Thanks to these solutions, the AP1000 is regarded as a modern solution that can play a significant role in the future of nuclear energy, reducing environmental impact and enhancing safety.

9.2.3. Safety assessment of the retrofit – Technical aspects

Replacing the existing units at the Kozyenice power plant with new units equipped with AP1000 nuclear reactors involves a number of technological safety aspects. The AP1000 reactor, designed by Westinghouse, is one of the modern Generation III+ pressurised water reactors, distinguished by its advanced safety systems.

9.2.3.1. Passive safety systems

AP1000 reactors feature advanced passive safety systems that differ from traditional technologies based mainly on active electrically powered systems. The main features of this system are:

- **Passive core cooling:** In the event of a failure, the AP1000 reactor uses natural coolant circulation and gravity to remove excess heat, which minimises dependence on electrical power and reduces the risk of large-scale failure.
- **Pressurised systems and condensation pools:** In addition, the AP1000 has systems that ensure cooling by transferring heat from the reactor to the environment without the need for an external source of water or energy.
- **Passive containment cooling:** The primary containment of the AP1000 reactor is a steel vessel surrounded by a containment building in such a way that two concentric vertical gaps are created between the walls of these structures, forcing air to flow through natural circulation. This is an essential element of passive containment cooling and the reduction of overpressure within it. In the event of insufficient cooling, this system is supported by spraying the steel shell with water flowing by gravity from a pool located at the upper part of the containment building.

9.2.3.2. Seismic safety and structural resilience

The AP1000 is designed to meet high standards of seismic safety and resistance to extreme weather events. The reactor design includes:

- **Appropriate reinforcement of the reactor building:** The structure is protected against earthquakes, external impacts, e.g., caused by a plane crash, and other external hazards.
- **Multi-layered safety enclosure:** A thick dome covering the reactor provides additional protection against the release of radioactive substances to the outside in the event of internal accidents.

9.2.3.3. Automation and redundancy of safety systems

The AP1000 reactor is controlled by advanced automation systems that enable rapid and effective response to failures. Its distinguishing features include:

- **Redundant control and safety system:** Multi-level safeguards and redundancy of key subsystems minimise the risks associated with human error or failures of individual system components.
- **Automatic reactor shutdown:** If necessary, the reactor can be automatically and safely shut down, ensuring better management of critical situations.

9.2.3.4. Minimising the risk of core meltdown

One of the key safety objectives in the AP1000 is to reduce the risk of accidents such as core meltdowns, which have occurred in the past (e.g., at Fukushima). Thanks to passive cooling systems and resistance to power loss, the reactor can cool down safely for an extended period of time, which is vital in the event of a prolonged power outage or other emergency.

9.2.3.5. Waste management and radiation aspects

Waste management systems in AP1000 reactors also meet stringent safety requirements:

- Reduction of radioactive waste: The technologies used minimise the amount of radioactive waste generated and enable its safe storage.
- Radiation protection: The reactor infrastructure provides multi-layered radiation protection, safeguarding personnel and the environment surrounding the power plant.

9.2.3.6. Integration with the existing infrastructure in Koźlenice

Replacing the units in Koźlenice with AP1000 reactors would require infrastructure adaptation, including modernisation of cooling systems, connections to the power grid and the construction of facilities for safe waste management. Another important aspect is ensuring adequate staff training and implementation of advanced operational and maintenance safety procedures.

9.2.3.7. Physical security requirements

Investments in AP1000 reactors must take into account systems for protection against physical threats such as terrorism or sabotage. The use of modern monitoring systems, perimeter protection and anti-intrusion measures is crucial.

Replacing the existing power units in Koźlenice with AP1000 reactors offers a number of technological advantages from a safety perspective, mainly due to passive safety systems, structural resilience, system automation and advanced radiation protection and risk management solutions. However, the implementation of such a project would require careful planning, adaptation of the existing infrastructure and compliance with detailed regulatory requirements.

9.2.4. Safety assessment of the retrofit – Organisational aspect – emergency planning zones

The designation of the emergency planning zone (EPZ) for a nuclear power plant with two AP1000 reactors at the site of the existing Koźlenice power plant is a process that must take into account both international standards and national regulations on nuclear safety.

9.2.4.1. Exclusion Zone

- This is the immediate area around the power plant, access to which is strictly controlled and restricted to power plant personnel and essential services.
- Its radius is typically 500–1,000 metres from the reactors. Appropriate safety measures, such as radiation monitoring and physical protection systems, are provided in this zone.

9.2.4.2. Precautionary Action Zone (PAZ)

- The PAZ covers an area within which rapid precautionary measures (e.g., sheltering of the population, evacuation) can be taken in the event of a potential accident.
- In accordance with the recommendations of the International Atomic Energy Agency (IAEA) and the practice for reactors such as AP1000, the typical radius of this zone is 3–5 kilometres around the power plant.
- Detailed evacuation procedures and warning systems are developed for this zone to ensure rapid action in the event of a serious threat being detected.

9.2.4.3. Urgent Protective Action Planning Zone (UPZ)

- This zone covers an area where protective measures such as evacuation, the distribution of iodine tablets or monitoring of radiation levels may be necessary in the event of an accident involving the potential release of radioactive materials.
- For AP1000 reactors, the UPZ zone extends up to 15–20 kilometres from the power plant.
- This area should have contingency plans in place, which may include cooperation with local authorities, emergency communication systems and public information measures.

9.2.4.4. Extended Planning Distance (EPD)

- Within the wider planning area, long-term measures may be required, such as monitoring the environmental condition and public health.
- For AP1000 reactors and in accordance with international practices, this area may cover a radius of up to 50–80 kilometres from the power plant. In this zone, it is particularly important to monitor potential contamination of soil, water and air.

The organisation of emergency zones should take into account the specific characteristics of the Kozienice location. The area around Kozienice and the demographic and geographical features of the region may influence the detailed boundaries and shape of the SPA zones. It is important to take into account factors such as population density, the location of evacuation routes and the proximity of critical infrastructure. The National Atomic Energy Agency will be the key authority approving the detailed SPA plans, which must comply with national regulations and civil protection standards. Regular exercises involving local authorities, emergency services and residents will be necessary to ensure the effectiveness of emergency response procedures.

In general, preliminary work involves establishing guidelines for the internal and external emergency planning zones, as shown schematically in the figure.

9.3. Summary

From a legal perspective, the siting of a nuclear power plant at the location under consideration is feasible, and the project under review meets all the requirements set out in the REGULATION OF THE COUNCIL OF MINISTERS of 31 August 2012 on nuclear safety and radiological protection requirements to be taken into account in the design of a nuclear facility (Journal of Laws 2012, item 1048 - *Dz.U. 2012, poz. 1048*).

An organisational safety assessment of the project is, in principle, possible after reviewing the detailed project documentation and its implementation. It should be assumed that it will be prepared in accordance with the applicable standards and engineering best practices.

The selected design solution more than meets the requirements for basic safety indicators, and the use of passive safety systems deserves special mention.

10. Identification of legal and regulatory barriers to the investment process

The implementation of 'coal-to-nuclear' investments (i.e., the replacement of coal-fired power generation in the area with nuclear power), despite their potential benefits, may encounter numerous legal and regulatory barriers. The complexity of administrative procedures and the inadequacy of existing regulations to the requirements of such projects can significantly hinder their implementation. An important element of the preliminary feasibility study for a 'coal-to-nuclear' investment is understanding the procedural pathway required to obtain a construction permit and identifying key legal and legislative barriers.

10.1. Description of the procedural pathway for obtaining a construction permit for a nuclear facility

A construction permit for a nuclear facility is an essential document enabling the commencement and conduct of construction works. Before submitting an application for its issuance, the investor must prepare design documentation compliant with legal requirements and obtain a number of formal documents and administrative decisions. In the case of nuclear facilities, this process encompasses both the standard building procedure and an additional pathway that takes into account the specific requirements associated with nuclear proceedings.

The standard building procedure is based on the Act of 7 July 1994 – Construction Law (Journal of Laws 2024, item 725 - *Dz. U. 2024 poz. 725*), hereinafter referred to as the Construction Law. This legal Act regulates the construction process, including investment preparation, obtaining a construction permit, the execution of construction works, commissioning of facilities and their maintenance in a proper technical condition. The Act defines the rights and obligations of participants in the investment process, indicates structures requiring a building/demolition permit or notification, describes the procedures for obtaining them and the operating principles of public administration bodies. It also specifies the requirements for design documentation and formalities necessary in the construction process. The technical documentation required when submitting an application for a construction permit consists of three elements: two parts of the construction project – the land development plan and the architectural and construction design. The third part, i.e., the technical design, must be prepared and kept on the construction site before work begins. All elements of the construction project must be signed by engineers with the appropriate qualifications, in accordance with the scope of the documentation.

The nuclear procedure and the additional requirements and simplifications applicable therein result from the Act of 29 November 2000 – Atomic Law (Journal of Laws 2024.1277 - *Dz.U.2024.1277*), hereinafter referred to as the Atomic Law, and the Act of 29 June 2011 on the preparation and implementation of investments in nuclear energy facilities and accompanying investments (Journal of Laws 2024, item 1410 - *Dz. U. 2024 poz. 1410*), hereinafter referred to as the Special Act. The body responsible for issuing decisions within the nuclear path is the National Atomic Energy Agency (*Państwowa Agencja Atomistyki - PAA*), represented by the President of the PAA.

The first and one of the most important decisions in the process of constructing a nuclear facility is the **fundamental decision** issued by the minister responsible for energy at the request of the investor. This document specifies the permitted parameters of the investment related to the construction of a nuclear power plant. It also constitutes the basis for applying for further administrative decisions, including the decision on determining the location of the investment in the construction of a nuclear power plant and other permits necessary for the preparation, implementation and use of the facility. The purpose of the fundamental decision is to protect the public interest, in particular in the context of implementing state policy objectives, such as energy policy, and ensuring national security (Article 3a of the Special Act).

The fundamental decision enables the investor, among other things, to submit an application for a **decision on environmental conditions** (*decyzji o środowiskowych uwarunkowaniach - abbreviated as DoŚU*), which is necessary in the further process of obtaining a construction permit for a nuclear facility. DoŚU is issued for projects that may always have a significant impact on the environment and for projects that may potentially have a significant impact on the environment. The rules for issuing it are regulated by the Act of 3 October 2008 on access to information on the environment and its protection, public participation in environmental protection and environmental impact assessments (Journal of Laws 2024.1112 - *Udziale społeczeństwa w ochronie środowiska oraz o ocenach oddziaływania na środowisko (Dz.U.2024.1112)*). The EIA is intended to ensure that the planned investment has the least possible negative impact on the environment. If the investment may have a significant impact on the environment, an environmental impact assessment is carried out before a decision on environmental conditions is issued. The assessment is based on an environmental impact report prepared by the applicant. This report presents data on the impact of the investment on the environment, covering both the methods of construction and the operational phase, taking into account aspects such as noise, emissions and the impact on residents.

For energy facilities classified in the third geotechnical category, such as nuclear power plants, it is also necessary to prepare **geological and engineering documentation** (*dokumentacji geologiczno-inżynierskiej - abbreviated as DGI*), which is attached to the construction design as part of the technical design. The requirement to prepare DGI stems from the Act of 9 June 2011 Geological and Mining Law (Journal of Laws 2024, item 1290 - *ustawy z dnia 9 czerwca 2011 r. Prawo geologiczne i gornicze (Dz.U. 2024 poz. 1290)*) and the implementing acts to this Act, including the Regulation of the Minister of the Environment of 18 November 2016 on hydrogeological documentation and geological and engineering documentation (Journal of Laws 2016, item 2033 - *Dz.U. 2016 poz. 2033*) and the Regulation of the Minister of Transport, Construction and Maritime Economy of 25 April 2012 on determining the geotechnical conditions for the foundation of buildings (Journal of Laws 2012, item 463 - *Dz.U. 2012 poz. 463*).

Geological and engineering documentation (DGI) should be prepared independently of the obligation to prepare a geotechnical opinion, ground investigation documentation and a geotechnical design. In accordance with the provisions of the Geological and Mining Law, DGI requires approval by the competent authorities. The process begins with the development of a Geological Works Project, which is agreed upon and approved in the form of an administrative decision. After its approval and notification of the intention to commence field work, the planned geological works (at the earliest 2 weeks after approval), laboratory tests and analyses necessary for the preparation of the DGI are carried out. Once the documentation is complete, an application for its approval must be submitted. The decision in this matter is issued by the district administrator (assisted by the district geologist) or the provincial governor (with the assistance of the provincial geologist).

The next step in the investment process is to obtain a **decision on the location of the investment for the construction of a nuclear power plant**, which is issued by the locally competent provincial governor. Pursuant to Article 15(6) of the Special Act, this decision replaces the decision on development conditions required in the standard procedure (for non-nuclear investments) in the absence of a current Local Spatial Development Plan. The decision on the location of the investment grants the right to use the land necessary for its implementation. It includes, among other things, the designation of the property covered by the project, requirements for the protection of third party interests and conditions for the implementation of the investment, such as technical, environmental, conservation and fire safety requirements. The application for this decision must be supplemented by a number of opinions from other authorities, as specified in Article 5 of the Special Act.

A prerequisite for issuing a decision on determining the location of a nuclear energy facility investment is obtaining a prior decision on environmental conditions. It is worth noting that this decision may be submitted by the Investor in the course of proceedings for issuing a decision on determining the location of a nuclear energy facility investment.

In addition to the fundamental decision and the decision on the location, the investor should also obtain a **permit to carry out activities involving exposure related to the construction of a nuclear facility** (hereinafter referred to as a nuclear facility construction permit). One of the conditions for obtaining a permit for the construction of a nuclear facility is compliance with requirements concerning nuclear safety, radiological protection, physical protection and security of nuclear materials. In addition, the investor must ensure adequate financial resources for the completion of construction and maintenance of the safety of the nuclear facility (Article 38g(1) of the Atomic Law). The licence is issued by the President of the PAA within 24 months of the date of submission of the application together with the required documents. The application should include, among other things, a preliminary safety report, a location report, a design for the physical protection system for the nuclear facility and nuclear materials, a decision on environmental conditions, an opinion of the European Commission issued pursuant to Article 43 of the Treaty establishing the European Atomic Energy Community, as well as other documents specified in the Regulation of the Council of Ministers of 30 August 2021 on documents required when submitting an application for a licence to perform activities involving exposure to ionising radiation or when notifying the performance of such activities (Journal of Laws 2021.1667). The application must also be accompanied by **water law permits and notifications**, if required (Article 388(5) of the Water Law Act of 20 July 2017, Journal of Laws 2024.1087).

Upon receiving an application for a licence to construct a nuclear facility, the President of the PAA enables public participation in the proceedings by publishing the content of the application together with a summary safety report in the Public Information Bulletin. All interested parties may submit comments and motions, as well as participate in the administrative hearing (Article 39d of the Atomic Energy Act).

Pursuant to Article 39e of the Atomic Energy Act, when considering an application for a licence, the President of the PAA has the right to carry out inspections at the site where the activity covered by the application is planned. To this end, he may use the services of authorised laboratories and expert organisations, as well as require tests or expert opinions to be carried out in order to verify compliance with nuclear safety and radiation protection conditions.

Pursuant to Article 39f of the Atomic Energy Act, before issuing a licence, the President of the PAA submits a request to the Council for Nuclear Safety and Radiological Protection for an opinion on the draft licence. After obtaining this opinion, the draft is forwarded to the applicant, who has one month to submit comments. After considering these comments, the President of the PAA issues a decision on the granting of a licence for the construction of a nuclear facility. This decision, together with the content of the application and a summary safety report, is made public.

A licence for the construction of a nuclear facility specifies the conditions for carrying out the activities covered by the licence, including, inter alia, design requirements, the obligations of the organisational unit with regard to the safety of the nuclear facility, equipment, employees, the public and the environment, including radiation protection, emergency planning and procedures, nuclear facility management, and operating limits and conditions (Article 39g of the Atomic Law).

Obtaining a permit for the construction of a nuclear facility is a prerequisite for issuing a construction permit. It may be submitted by the investor in the course of proceedings for the issuance of a construction permit. The content of the permit, together with the decision on the location of the investment, is binding on the provincial governor who issues the construction permit (Article 15(2) of the Special Act).

The final stage of the procedural path for obtaining a construction permit for a nuclear facility is to submit an application for a **construction permit** together with the construction design and all necessary formal attachments. The entire application is reviewed by the competent administrative authority for compliance with the regulations. The first step in the verification process is to assess the completeness of the application (formal verification), which the authority is required to carry out within 14 days of its submission, in accordance with Article 33(6) of the Building Law. If the application contains formal deficiencies, the authority calls on the applicant to remedy them within a specified period. If the applicant is unable to remedy the deficiencies within the specified time, they have the right to submit a request for an extension of the proceedings. In such a situation, the administrative authority may postpone the procedure in accordance with Article 64 of the Code of Administrative Procedure (Journal of Laws 2024.572 - Dz.U.2024.572). After the applicant has made any corrections and the authority has accepted the application as valid, the office notifies the interested parties of the initiation of administrative proceedings. The next step is a substantive verification, during which the content of the application and attachments is analysed. Also at this stage, the architectural and construction authority has the right to request the applicant to correct any irregularities in the application, setting a deadline for their correction. The applicant may then supplement the documentation, provide additional explanations regarding the solutions used, or request the legal basis for the authority's request. After the design has been corrected/clarified, the authority may close the case by issuing a decision.

Once the construction permit has been obtained, a construction log is issued, a site manager is appointed, construction documentation is prepared, and then work can begin, starting with preparatory work and then moving on to the actual construction activities.

Apart from the main decisions described in this chapter, and depending on the scope and complexity of the investment, other decisions and agreements may be required under separate regulations (e.g. permission to cut down trees, permission to access a public road if the investment is located on a national or provincial road, etc.). Most often, these decisions are attached to the construction permit application.

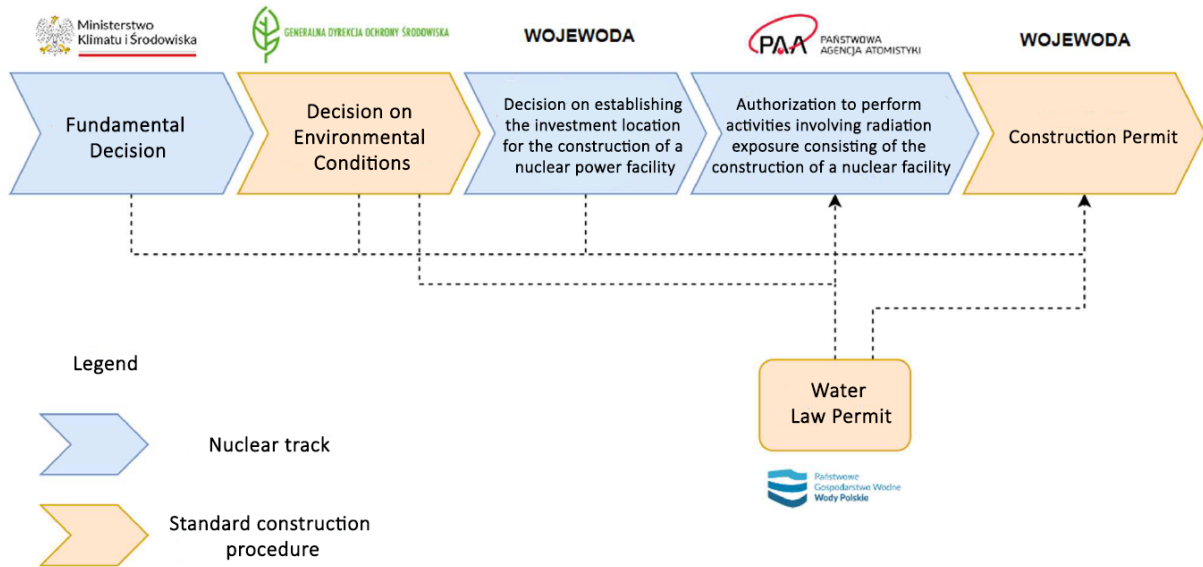

Figure 46 Simplified diagram showing the process of obtaining a construction permit for a nuclear facility

10.2. Legal and legislative barriers to the investment process

Obtaining a construction permit to build a nuclear power plant in Poland is a complex process that faces numerous legal barriers. An analysis of the Atomic Energy Act, the Construction Act and the Special Act indicates the following obstacles:

10.2.1. Dispersed and imprecise regulations

The regulations governing the process of obtaining a construction permit for a nuclear facility are scattered across numerous legal acts, which makes their interpretation and application difficult. The Atomic Energy Act and the Special Act introduce certain simplifications, but they do not eliminate all barriers. Furthermore, the applicable legal regulations contain provisions that are sometimes unclear and leave considerable room for interpretation.

10.2.2. Lack of experience among the administrative bodies involved in issuing decisions in the process of obtaining the necessary permits and authorisations

One of the significant barriers to obtaining a construction permit for nuclear power plants in Poland is the lack of experience of administrative authorities. To date, no such investment project has been carried out in Poland, which means that officials and institutions responsible for project assessment lack adequate practical experience in the specific requirements of such undertakings.

The process of obtaining permits for the construction of a nuclear power plant is complex and requires consideration of numerous legal, technical, environmental and construction aspects. Of particular importance is the precise application of regulations pertaining to nuclear safety and radiological protection, as well as compliance with national technical and construction standards.

A lack of prior experience in assessing this type of investment may lead to a prolonged decision-making process and ambiguous interpretation of regulations. In addition, administrative authorities may adopt an overly cautious approach in an effort to avoid potential errors, which may result in the imposition of additional requirements and delays in project implementation.

10.2.3. Two separate assessment pathways for nuclear power plant construction projects and the lack of a separate derogation pathway for nuclear facilities

Under the Polish legal system, the construction of a nuclear power plant is subject to assessment by two separate authorities: the President of the PAA and the provincial governor. The problem stems from the different assessment criteria adopted by these authorities. The President of the PAA focuses on nuclear safety and radiation protection, permitting solutions based on foreign norms and standards provided they are confirmed by international certificates. Such a system allows for a certain degree of flexibility in the approach to projects, especially in the case of 'standard plant' projects, which are based on proven solutions used worldwide and which can be adapted to Polish conditions. In contrast, the provincial governor, must strictly apply Polish technical and construction regulations.

In practice, this means that 'standard plant' designs, although based on recognised foreign standards, must be adapted to the requirements of Polish construction law. The Special Act does not provide for an exemption from the requirement to comply with national technical and construction regulations, which means that 'standard plant' designs often require modifications or the granting of exemptions. In the case of derogations, there is no separate procedure for nuclear facilities, which means that the President of the PAA does not participate in the process of granting derogations. As a result, a situation may arise in which a design meets nuclear safety requirements but is not approved by the provincial governor due to non-compliance with local building regulations, or vice versa.

10.2.4. No pathway for adapting existing facilities

One of the significant legal barriers in the process of implementing investments related to the construction of nuclear power plants is the lack of regulations concerning the adaptation of existing facilities, installations or infrastructure to the requirements of such projects. Facilities originally designed and used for other purposes may not meet the technical and formal standards necessary for operation within a nuclear power plant.

Current regulations do not provide for a dedicated procedural path that would allow for the conversion and adaptation of existing buildings, installations or infrastructure elements in a manner consistent with the requirements for radiological protection and nuclear safety in the construction of a nuclear power plant. There are also no guidelines specifying the scope and type of technical documentation that would need to be submitted in the event of such adaptation in order to document compliance with nuclear safety requirements.

10.2.5. Recommendations:

- Developing and implementing detailed legal provisions enabling the conversion of facilities originally designed for other purposes in a manner consistent with the requirements for nuclear power plants.
- Preparation of detailed guidelines specifying the technical standards that adapted facilities must meet in order to be eligible for use as part of a nuclear power plant infrastructure. These guidelines should also cover the type and scope of technical documentation required to demonstrate compliance with safety standards.
- Introduction of a procedure enabling the assessment of the compliance of adapted facilities with technical requirements and requirements concerning radiological protection and nuclear safety. This process could be carried out by supervisory authorities such as the National Atomic Energy Agency.

11. Investment Schedule

We assume that the project in Kozienice will start in 2026 and run until 2046, thus spanning a period of twenty years.

The first stage is the study and analysis phase, which will begin in 2026 with the preparation of a feasibility study. The following year, in 2027, the investor is expected to make a decision on proceeding with the investment, which paves the way for the start of a complex and protracted process of obtaining administrative and environmental decisions. This stage runs until 2032 and will include the preparation of documentation related to environmental impact, the Fundamental Decision and the location decision.

From 2032, the permit acquisition phase begins. The permit for preparatory works will be issued in the same year, while the construction design will be drawn up in 2033–2034. During the same period, procedures related to the issuance of a construction permit will be carried out. The formal completion of this phase is scheduled for 2034, which will enable the transition to the construction phase.

The design and procurement phase will commence in 2034. During this time, the design and ordering of components for two units will be carried out. For the first unit, this period will last from 2034 to 2042, and for the second unit from 2035 to 2043, taking into account the one-year offset between the units. These processes will be carried out in parallel with other activities, allowing for more effective management of the investment timeline. Orders and deliveries for the first unit will take place between 2036 and 2042, and for the second unit between 2037 and 2043.

Preparatory work on the investment site will be in progress from 2033. Construction of the power units will begin in 2034 – for the first unit – and a year later for the second. The construction of each unit takes eight years. Construction of the first unit will be completed in 2042, and the second in 2043. The first concrete pour, marking the symbolic start of reactor construction, is scheduled for 2035 and 2036, respectively.

Once construction is complete, the testing and commissioning phase begins. For the first unit, testing is scheduled for 2041–2043, with commissioning between 2042 to 2044. The operating licence is expected to be granted in 2044. For the second unit, testing will take place between 2042 and 2044, with commissioning between 2043 and 2045. The operating licence for this unit will be issued in 2045, completing the entire project in 2046.

The schedule includes the decommissioning of existing coal-fired power units in 2032.

The entire structure of the schedule is based on the parallel execution of multiple activities, both technical and formal. The project is highly complex, particularly due to the construction of two independent but interconnected nuclear units. The use of long-term planning with overlapping design, procurement and construction phases indicates a strategic approach to reducing the overall project implementation time. At the same time, such a schedule requires a high level of coordination and flexibility in resource and risk management.

Like other nuclear projects, this one must take into account specific requirements relating to safety, quality of workmanship and compliance with stringent legal regulations. With this in mind, the schedule in Koźienice is realistic, albeit very demanding, and forms the basis for the long-term transformation of Poland's energy system.

12. SWOT analysis

Table 30 SWOT analysis

	POSITIVE	NEGATIVE
INTERNAL	<p>STRENGTHS</p> <ul style="list-style-type: none"> • Increased energy security • Restoration of generation capacity to a level similar to the current one (approx. 2,200 MW) • Opportunity to utilise local human resources and local businesses • Reduction in the emissions intensity of electricity generation compared to coal-fired power plants 	<p>WEAKNESSES</p> <ul style="list-style-type: none"> • Limited possibility of using the existing technical infrastructure of the facility under consideration • Need to vacate the entire area of existing 200 MW and 500 MW units and their auxiliary facilities • Aligning the investment schedule to the decommissioning of coal-fired power units • High capital expenditure compared to other technologies
EXTERNAL	<p>OPPORTUNITIES</p> <ul style="list-style-type: none"> • Implementation of plans to decarbonise the Polish energy sector in line with the Coal-to-Nuclear concept • Local development – the power plant remains in Kozienice • Preserving/creating jobs, and reduction of the adverse impact on the local aquatic environment of the Vistula River, which may lead to better cooperation with environmental organisations 	<p>THREATS</p> <ul style="list-style-type: none"> • Construction of a nuclear reactor on the site of a former coal-fired power plant • Financing – difficulty with securing financing • Adaptation of regulations to the Coal-to-Nuclear approach • Accumulation of nuclear investments at a single point in time

Tributary Canal
Vistula

Tributary Canal
Vistula

Direction of Transport from
'Main Gate'

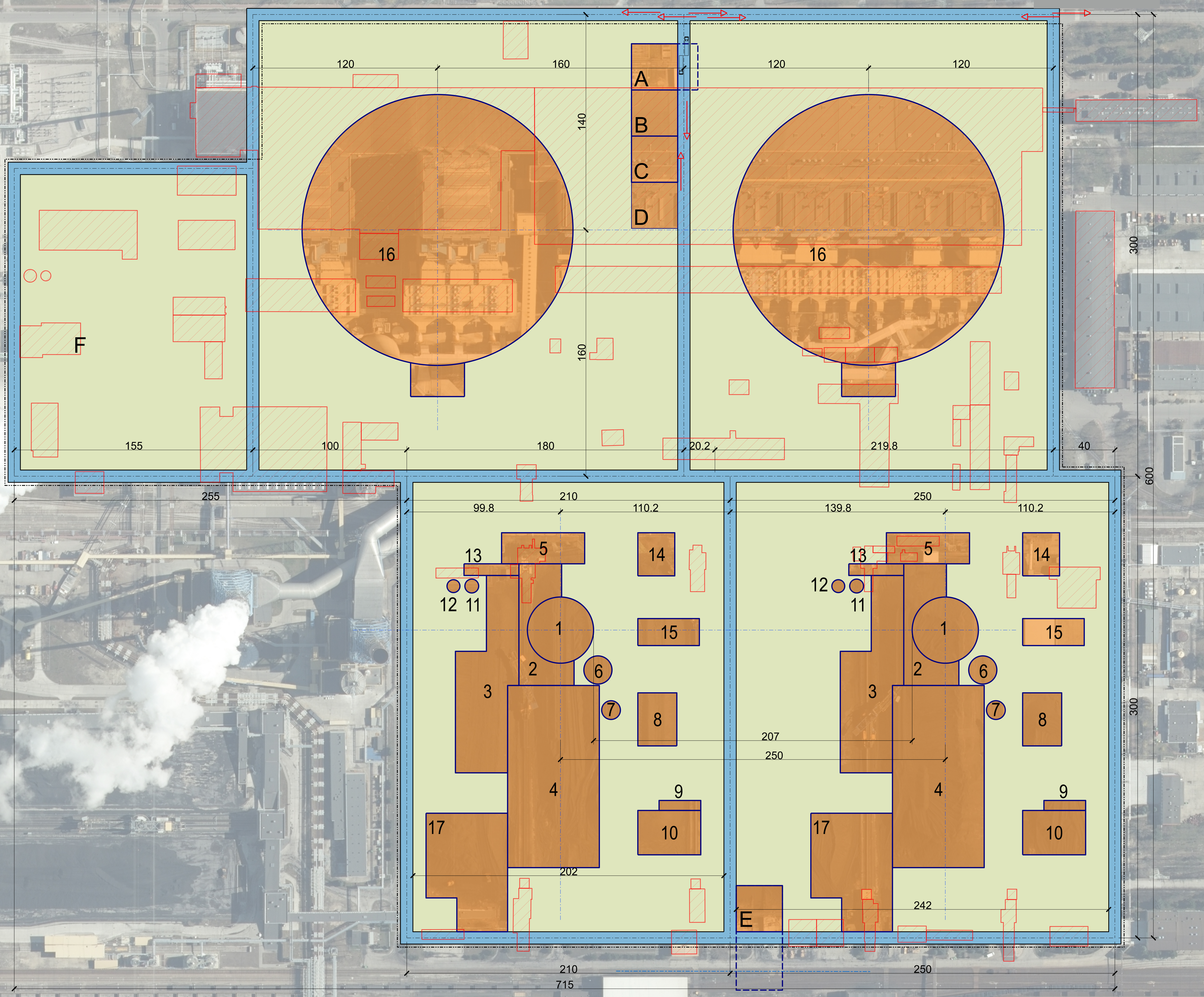

Key	
1	Reactor building (containment & shield building)
2	Auxiliary building
3	Reactor support building
4	Turbine building (machine hall)
5	Radioactive waste building
6	Water tank for passive containment cooling
7	Condensate tanks
8	Service water system coolers
9	Fire water pumping station
10	Fire water tanks
11	Deionised water tank
12	Boric acid tank
13	Spent fuel transport container platform
14	Diesel generator building
15	Diesel fuel tanks for the generator set
16	Cooling tower
17	Transformer system
Key - Auxiliary facilities	
A	Road and pedestrian transport, monitoring control building
B	Staff facilities (dishes, sanitary building)
C	Workshop and storage building
D	Storage yard
E	Radioactive monitoring control building
F	Site reservation

LEGEND:	
	PLANNED ROADS
	EXISTING BUILDINGS AND STRUCTURES TO BE DEMOLISHED
	PLANNED BUILDINGS AND STRUCTURES
	PLANNED LAND USE
	EXISTING RAILWAY TRACK
	PLANNED FENCING
	LAND WITH EXISTING BUILDINGS, OBJECTS, AND INSTALLATIONS THAT WILL BE UTILISED AND ADAPTED FOR THE NEEDS OF THE PLANNED NEW TECHNOLOGY

Prepared by: Aleksandra Trembaczevska
 Approved by: Janusz Jankowiak

Plan of decarbonisation of Poland's domestic power industry through modernisation with the use of nuclear reactors
 PRELIMINARY FEASIBILITY STUDY FOR KOZIECIN
 LAND USE PLAN

Date: 30.06.2025
 Drawing: ZAL-1
 Form: AD
 Scale: 1:1000

KM4.1 PRELIMINARY FEASIBILITY STUDIES FOR GEN III REACTORS KOZIECIN

Appendix 2 – Investment Schedule

KM4.1 Preliminary feasibility studies for Generation III reactors – Kozenice

No.	Task Name	Duration (Months)	Start	End
0	Kozenice – timetable	243.83	01-2026	01-2046
1	Study and analysis phase	243.83	01-2026	01-2046
2	Preparation of the feasibility study	12	01-2026	12-2026
3	Investor's decision to proceed with the project	0	01-2027	01-2027
4	ROŚ, PSAR, decisions: in-principle, environmental, on site selection, etc.	66	01-2027	07-2032
5	FSAR (Final Safety Analysis Report) including updates	120	03-2036	01-2046
6	Permits	25	07-2032	07-2034
7	Permit for preparatory works	1	07-2032	08-2032
8	Construction design	12	06-2033	06-2034
9	Building permit	24	07-2032	06-2034
10	Building permit (statutory, excluding exemptions)	1	06-2034	07-2034
11	Design and supplies	112	06-2034	09-2043
12	Unit 1	100	06-2034	09-2042
13	Design of Unit 1 with a nuclear reactor	100	06-2034	09-2042
14	Procurement and supplies	78	04-2036	09-2042
15	Unit 2	100	06-2035	09-2043
16	Design of Unit 2 with a nuclear reactor	100	06-2035	09-2043
17	Procurement and supplies	78	04-2037	09-2043
18	Coal-fired units	0	12-2032	12-2032
19	Decommissioning of coal-fired units	0	12-2032	12-2032
20	Construction of power units with a nuclear reactor	158.73	01-2033	01-2046
21	Preparatory works	36	01-2033	12-2035
22	Unit 1	127.83	07-2034	01-2045
23	Construction of Unit 1 with a nuclear reactor	96	07-2034	06-2042
24	First concrete (nuclear)	0	03-2035	03-2035
25	Tests	24	10-2041	10-2043
26	Operating licence	0,5	06-2042	06-2042
27	Start-up licence	9	11-2041	08-2042
28	Start-up	24	08-2042	07-2044
29	Operating permit	6	07-2044	01-2045
30	Unit 2	127.83	07-2035	01-2046
31	Construction of Unit 2 with a nuclear reactor	96	07-2035	06-2043
32	First concrete (nuclear)	0	03-2036	03-2036
33	Tests	24	10-2042	09-2044
34	Operating licence	0,5	06-2043	06-2043
35	Start-up licence	9	11-2042	07-2043
36	Start-up	24	07-2043	07-2045
37	Operating permit	6	07-2045	01-2046

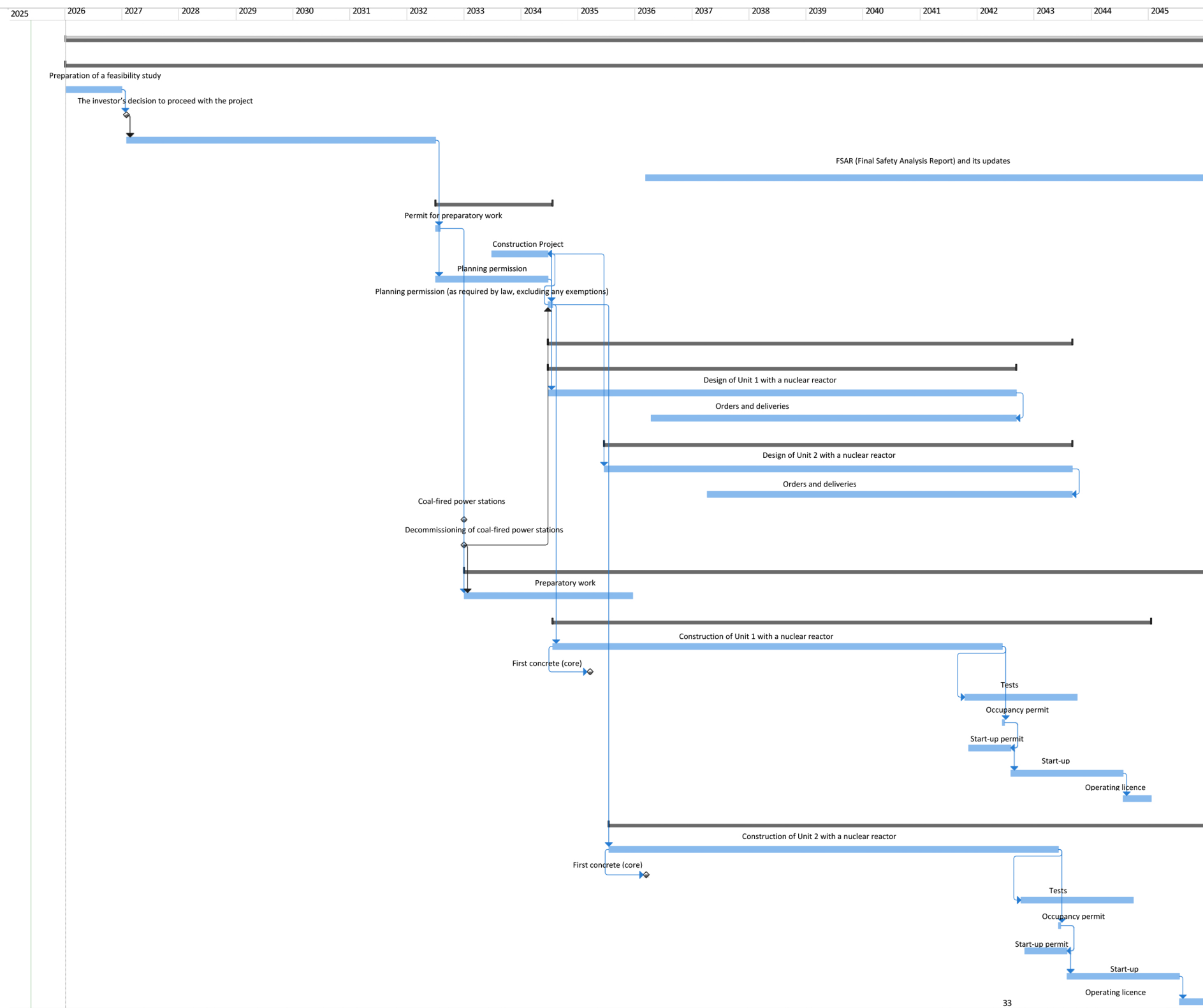

Appendix 3

KM4.1 Preliminary feasibility studies for Generation III reactors – Kozenice

The table below shows a breakdown of jobs in nuclear and coal-fired power stations, specifying the number of posts in 1000 MW power stations based on¹

SOC Classification	Position (Original Polish)	Position (English Translation)	Number of posts eliminated	Number of posts created	Difference
13-2011	Księgowi i audytorzy	Accountants and auditors	-1,35	1,44	0,09
11-3010	Kierownicy ds. usług administracyjnych i obiektów	Administrative services and facilities managers	-1,05	2,88	1,83
11-9041	Kierownicy ds. architektury i inżynierii	Architectural and engineering managers	-1,2	9,36	8,16
49-3023	Technicy i mechanicy serwisu samochodowego	Automotive service technicians and mechanics	-0,3	0	-0,3
43-3011	Windykatorzy i windykatorzy	Bill and account collectors	-0,3	0	-0,3
43-3021	Pracownicy ds. rozliczeń i księgowości	Billing and posting clerks	-0,15	0	-0,15
43-3031	Pracownicy ds. księgowości, audytu i audytu	Bookkeeping accounting, and auditing clerks	-0,6	0	-0,6
13-2031	Analitycy budżetowi	Budget analysts	-0,15	0	-0,15
49-3031	Mechanicy autobusów i ciężarówek oraz specjaliści ds. silników wysokoprężnych	Bus and truck mechanics and diesel engine specialists	-0,6	0	-0,6
13-1020	Nabywcy i agenci ds. zakupów	Buyers and purchasing agents	-1,2	2,16	0,96
17-3098	Technolodzy i technicy kalibracji oraz technologowie i technicy inżynierii, z wyjątkiem kreślarzy, wszyscy inni	Calibration technologists and technicians and engineering technologists and technicians, except drafters, all other	-0,6	0	-0,6
17-2041	Inżynierowie chemicy	Chemical engineers	0	1,08	1,08
19-4031	Technicy chemiczni	Chemical technicians	-0,6	2,52	1,92
19-2031	Chemicy	Chemists	-0,45	2,52	2,07
11-1011	Dyrektorzy naczelni	Chief executives	-0,15	0	-0,15
17-2051	Inżynierowie budownictwa	Civil engineers	-0,3	0	-0,3
13-1041	Specjaliści ds. zgodności	Compliance officers	-0,75	2,16	1,41
11-3021	Menedżerowie systemów komputerowych i informacyjnych	Computer and information systems managers	-0,75	1,08	0,33
15-1241	Architekci sieci komputerowych	Computer network architects	-0,3	0	-0,3

¹ Hansen J., Jenson W., Wrobel A., Stauff N., Biegel K., Kim T., Belles R., Omिताamu F.: Investigating Benefits and Challenges of Converting Retiring Coal Plants into NuclearPlants. Systems Analysis and Integration; Revision 2 Prepared for U.S. Department of Energy September 13, 2022 ;INL/RPT-22-67964

SOC Classification	Position (Original Polish)	Position (English Translation)	Number of posts eliminated	Number of posts created	Difference
15-1231	Specjaliści ds. wsparcia sieci komputerowych	Computer network support specialists	-0,3	0,72	0,42
15-1299	Zawody komputerowe, wszystkie inne	Computer occupations, all other	-0,15	1,08	0,93
15-1251	Programiści komputerowi	Computer programmers	-0,15	0	-0,15
15-1211	Analitycy systemów komputerowych	Computer systems analysts	-1,35	2,16	0,81
15-1232	Specjaliści ds. wsparcia użytkowników komputerów	Computer user support specialists	-0,75	0,72	-0,03
47-2061	Robotnicy budowlani	Construction laborers	-0,15	0	-0,15
11-9021	Budownictwo menedżerowie	Construction managers	-0,6	0	-0,6
49-9012	Instalatorzy i naprawiacze układów sterowania i zaworów, z wyjątkiem drzwi mechanicznych	Control and valve installers and repairers, except mechanical door	-3,45	0,72	-2,73
51-9021	ustawiacze, operatorzy i przetargowcy maszyn do kruszenia, szlifowania i polerowania	Crushing grinding, and polishing machine setters, operators, and tenders	-0,3	0	-0,3
43-4051	Przedstawiciele obsługi klienta	Customer service representatives	-5,25	0	-5,25
15-1245	administratorzy baz danych i architektki	Database administrators and architects	-0,15	0	-0,15
43-5032	dyspozytorzy, z wyjątkiem policji, straży pożarnej i pogotowia ratunkowego	Dispatchers, except police, fire, and ambulance	-0,45	0	-0,45
17-3023	Technolodzy i technicy inżynierii elektrycznej i elektronicznej	Electrical and electronic engineering technologists and technicians	-1,95	2,16	0,21
17-3012	kreślarze elektryczni i elektroniczni	Electrical and electronics drafters	-0,45	0	-0,45
49-2094	Naprawiacze urządzeń elektrycznych i elektronicznych, sprzęt komercyjny i przemysłowy	Electrical and electronics repairers, commercial and industrial equipment	-0,75	0,72	-0,03
49-2095	Naprawiacze urządzeń elektrycznych i elektronicznych, elektrownie, podstacje i przekaźniki	Electrical and electronics repairers, powerhouse, substation, and relay	-7,8	10,44	2,64
17-2071	Inżynierowie elektrycy	Electrical engineers	-6,75	9,72	2,97
49-9051	Instalatorzy i naprawiacze linii energetycznych	Electrical power-line installers and repairers	-10,2	2,52	-7,68
47-2111	Elektrycy	Electricians	-3	5,76	2,76
17-2072	Inżynierowie elektronicy, z wyjątkiem komputerów	Electronics engineers, except computer	-0,15	0,72	0,57

SOC Classification	Position (Original Polish)	Position (English Translation)	Number of posts eliminated	Number of posts created	Difference
11-9161	Dyrektorzy ds. zarządzania kryzysowego	Emergency management directors	0	1,08	1,08
17-2199	Inżynierowie, wszyscy inni	Engineers, all other	-0,6	2,16	1,56
17-2081	Inżynierowie środowiska	Environmental engineers	-0,15	0,72	0,57
19-4042	Technicy nauk o środowisku i ochrony, w tym służby zdrowia	Environmental science and protection technicians, including health	0	1,08	1,08
19-2041	Naukowcy i specjaliści ds. środowiska, w tym służby zdrowia	Environmental scientists and specialists, including health	-0,45	1,08	0,63
47-5022	operatorzy maszyn do kopania i ładowania oraz koparek linowych, górnictwo odkrywkowe	Excavating and loading machine and dragline operators, surface mining	-0,15	0	-0,15
43-6011	Sekretarki wykonawcze i asystenci administracyjni	Executive secretaries and executive administrative assistants	-0,9	2,52	1,62
43-4071	Urzędnicy ds. archiwów	File clerks	0	0,72	0,72
13-2098	Analitycy finansowi i inwestycyjni, specjaliści ds. ryzyka finansowego i specjaliści ds. finansów, wszyscy inni	Financial and investment analysts, financial risk specialists, and financial specialists, all other	-1,05	1,44	0,39
11-3031	Kierownicy finansowi	Financial managers	-0,6	0,72	0,12
47-1011	Kierownicy pierwszej linii zawodów budowlanych i pracowników wydobywczych	First-line supervisors of construction trades and extraction workers	-0,75	0,72	-0,03
49-1011	Kierownicy pierwszej linii mechaników, instalatorów i naprawców	First-line supervisors of mechanics, installers, and repairers	-4,5	8,64	4,14
43-1011	Przełożeni pierwszej linii pracowników wsparcia administracyjnego i biurowego	First-line supervisors of office and administrative support workers	-1,2	1,8	0,6
51-1011	Kierownicy pierwszej linii pracowników produkcyjnych i operacyjnych	First-line supervisors of production and operating workers	-6,3	17,28	10,98
53-1047	pierwsi kierownicy pracowników transportu i przenoszenia materiałów, z wyjątkiem kierowników obsługi ładunków lotniczych	First-line supervisors of transportation and material-moving workers, except aircraft cargo handling supervisors	-0,3	0	-0,3
19-1032	leśnicy	Foresters	-0,15	0	-0,15

SOC Classification	Position (Original Polish)	Position (English Translation)	Number of posts eliminated	Number of posts created	Difference
51-8092	Operatorzy gazowni	Gas plant operators	-0,75	0	-0,75
11-1021	Kierownicy generalni i operacyjni	General and operations managers	-2,7	2,52	-0,18
47-4041	Pracownicy usuwania materiałów niebezpiecznych	Hazardous materials removal workers	0	0,72	0,72
17-2111	Inżynierowie ds. zdrowia i bezpieczeństwa, z wyjątkiem inżynierów ds. bezpieczeństwa górnictwa i inspektorzy	Health and safety engineers, except mining safety engineers and inspectors	-0,15	0,72	0,57
53-3032	kierowcy ciężarówek i ciągników siodłowych	Heavy and tractor-trailer truck drivers	-0,15	0	-0,15
49-9098	pomocnicy — pracownicy instalacji, konserwacji i napraw	Helpers— installation, maintenance, and repair workers	-0,45	0	-0,45
51-9198	pomocnicy — pracownicy produkcji	Helpers—production workers	-0,3	0	-0,3
11-3121	Kierownicy ds. zasobów ludzkich	Human resources managers	-0,3	0,72	0,42
13-1071	Specjaliści ds. zasobów ludzkich	Human resources specialists	-0,6	1,08	0,48
17-3026	operatorzy ciężarówek i ciągników przemysłowych	Industrial engineering technologists and technicians	-0,15	1,44	1,29
17-2112	Kierownicy produkcji	Industrial engineers	-0,3	4,32	4,02
49-9041	Inżynierowie przemysłowi	Industrial machinery mechanics	-4,65	9,36	4,71
11-3051	Mechanicy maszyn przemysłowych	Industrial production managers	-1,2	3,96	2,76
53-7051	Przemysł inżynierowie technicy i technicy	Industrial truck and tractor operators	-0,6	0	-0,6
43-4199	Pracownicy ds. informacji i ewidencji, inni	Information and record clerks, all other	0	0,72	0,72
15-1212	Analitycy ds. bezpieczeństwa informacji	Information security analysts	-0,45	1,8	1,35
51-9061	Inspektorzy, testerzy, sorterzy, próbnicy i ważący	Inspectors, testers, sorters, samplers, and weighers	-0,3	1,44	1,14
49-9099	pracownicy instalacji, konserwacji i napraw, wszyscy inni	Installation, maintenance, and repair workers, all other	-0,15	0	-0,15
25-9031	Koordynatorzy ds. nauczania	Instructional coordinators	0	0,72	0,72
37-2011	sprzątacze i sprzątaczkę, z wyjątkiem pokojówek i sprzątarek	Janitors and cleaners, except maids and housekeeping cleaners	-0,15	0	-0,15
53-7062	Robotnicy i pracownicy transportu towarów, zapasów i materiałów, ręczni	Laborers and freight, stock, and material movers, hand	-0,9	1,08	0,18
23-1011	prawnicy	Lawyers	-0,45	0	-0,45

SOC Classification	Position (Original Polish)	Position (English Translation)	Number of posts eliminated	Number of posts created	Difference
13-1081	Logistycy	Logisticians	-0,75	0,72	-0,03
51-4041	Maszyniści	Machinists	-0,6	0,72	0,12
49-9071	Pracownicy ds. konserwacji i napraw, ogólnie	Maintenance and repair workers, general	-1,8	2,16	0,36
49-9043	pracownicy ds. konserwacji, maszyny	Maintenance workers, machinery	-0,45	0	-0,45
13-1111	Analitycy zarządzania	Management analysts	-2,1	2,16	0,06
13-1161	analitycy badań rynku i specjaliści ds. marketingu	Market research analysts and marketing specialists	-0,15	0	-0,15
11-2021	menedżerowie ds. marketingu	Marketing managers	-0,15	0	-0,15
17-2131	Inżynierowie materiałowi	Materials engineers	0	0,72	0,72
17-2141	Inżynierowie mechanicy	Mechanical engineers	-0,3	2,16	1,86
43-5041	odczytnicy liczników, media	Meter readers, utilities	-0,6	0	-0,6
49-9044	mechanicy	Millwrights	-0,3	0	-0,3
33-1090	Różni kierownicy pierwszej linii, pracownicy służb ochrony	Miscellaneous first-line supervisors, protective service workers	-0,15	4,68	4,53
49-3042	mechanicy mobilnego ciężkiego sprzętu, z wyjątkiem silników	Mobile heavy equipment mechanics, except engines	-0,6	0	-0,6
11-9121	Kierownicy nauk przyrodniczych	Natural sciences managers	0	0,72	0,72
15-1244	Administratorzy sieci i systemów komputerowych	Network and computer systems administrators	-0,45	1,44	0,99
17-2161	Inżynierowie nuklearni	Nuclear engineers	-0,45	44,64	44,19
51-8011	Operatorzy reaktorów jądrowych	Nuclear power reactor operators	-0,45	37,44	36,99
194051	Technicy nuklearni	Nuclear technicians	-0,9	24,48	23,58
19-5011	Specjaliści ds. bezpieczeństwa i higieny pracy	Occupational health and safety specialists	-0,75	4,32	3,57
19-5012	Technicy ds. bezpieczeństwa pożarowego i ochrony pracy	Occupational health and safety technicians	0	0,72	0,72
43-9061	Urzednicy biurowi, ogólnie	Office clerks, general	-1,05	3,96	2,91
47-2073	Inżynierowie operacyjni i inni pracownicy budowlani operatorzy sprzętu	Operating engineers and other construction equipment operators	-1,8	0	-1,8
15-2031	analitycy badań operacyjnych	Operations research analysts	-0,15	0	-0,15
23-2011	asystenci prawni i asystenci prawni	Paralegals and legal assistants	-0,15	0	-0,15
11-9198	Kierownicy ds. usług osobistych, wszyscy inni; menedżerowie ds.	Personal service managers, all other; entertainment and	-0,9	4,32	3,42

SOC Classification	Position (Original Polish)	Position (English Translation)	Number of posts eliminated	Number of posts created	Difference
	rozrywki i rekreacji, z wyjątkiem hazardu i menedżerów, wszyscy inni	recreation managers, except gambling and managers, all other			
19-2012	Fizycy	Physicists	0	0,72	0,72
51-8099	operatorzy instalacji i systemów, wszyscy inni	Plant and system operators, all other	-0,45	0	-0,45
47-2152	hydraulicy, monterzy rurociągów i monterzy instalacji parowych	Plumbers, pipefitters, and steamfitters	-0,6	0	-0,6
51-8012	Dystrybutorzy i dyspozytorzy energii elektrycznej	Power distributors and dispatchers	-3	1,08	-1,92
51-8013	Operatorzy elektrowni	Power plant operators	-25,35	2,16	-23,19
43-3061	Pracownicy ds. zaopatrzenia	Procurement clerks	0	0,72	0,72
51-9199	pracownicy produkcyjni, wszyscy inni	Production workers, all other	-0,15	0	-0,15
43-5061	Urzędnicy ds. produkcji, planowania i ekspedycji	Production, planning, and expediting clerks	-1,2	3,96	2,76
13-1198	Specjaliści ds. zarządzania projektami i specjaliści ds. operacji biznesowych, wszyscy inni	Project management specialists and business operations specialists, all other	-2,55	7,2	4,65
11-2030	menedżerowie ds. public relations i pozyskiwania funduszy	Public relations and fundraising managers	-0,3	0	-0,3
27-3031	specjaliści ds. public relations	Public relations specialists	-0,3	0	-0,3
11-3061	Kierownicy ds. zakupów	Purchasing managers	-0,15	0,36	0,21
11-2022	menedżerowie ds. sprzedaży	Sales managers	-0,15	0	-0,15
41-3091	przedstawiciele handlowi usług, z wyjątkiem reklamy, ubezpieczeń, usług finansowych i podróży	Sales representatives of services, except advertising, insurance, financial services, and travel	-0,3	0	-0,3
43-6014	Sekretarki i asystenci administracyjni, z wyjątkiem prawników, lekarzy i kadry kierowniczej	Secretaries and administrative assistants, except legal, medical, and executive	-1,65	2,52	0,87
33-9032	Strażnicy bezpieczeństwa	Security guards	-0,75	37,44	36,69
43-5071	pracownicy ds. wysyłki, odbioru i inwentaryzacji	Shipping, receiving, and inventory clerks	-0,15	0	-0,15
15-1256	Programiści oprogramowania oraz analitycy i testerzy ds. zapewniania jakości oprogramowania	Software developers and software quality assurance analysts and testers	-0,45	0,72	0,27
51-8021	inżynierowie stacjonarni i operatorzy kotła	Stationary engineers and boiler operators	-0,9	0	-0,9

SOC Classification	Position (Original Polish)	Position (English Translation)	Number of posts eliminated	Number of posts created	Difference
53-7065	Magazyniści i wypełniacze zamówień	Stockers and order fillers	-9	1,08	0,18
17-3031	Technicy geodezji i kartografii	Surveying and mapping technicians	-0,15	0	-0,15
53-7121	Ładowacze cystern, ciężarówek i statków	Tank car, truck, and ship loaders	-0,3	0	-0,3
27-3042	Autorzy techniczni	Technical writers	0	1,44	1,44
11-3131	Kierownicy ds. szkoleń i rozwoju	Training and development managers	-0,15	2,52	2,37
13-1151	Specjaliści ds. szkoleń i rozwoju	Training and development specialists	-0,75	9,72	8,97
11-3071	Kierownicy ds. transportu, magazynowania i dystrybucji	Transportation, storage, and distribution managers	-0,15	0,72	0,57
51-8031	Operatorzy zakładów i systemów uzdatniania wody i ścieków	Water and wastewater treatment plant and system operators	-1,05	0	-1,05
51-4121	Spawacze, przecinacze, lutownicy i lutownicy	Welders, cutters, solderers, and brazers	-1,5	0,72	-0,78
49-9081	Technicy serwisu turbin wiatrowych	Wind turbine service technicians	-0,3	0	-0,3